Instruction Manual (Supplementary) Totally-Enclosed Box Type Inverter TOSVERT **VF-S11**

Thank you for purchasing a Toshiba “Totally-enclosed box type TOSVERT VF-S11 series inverter.”
This Manual gives a supplementary explanation of some items referred to in the instruction manual E6581158 included with the product. Please read this manual carefully along with the instruction manual E6581158.



1-phase 240V class	0.2 to 2.2kW
3-phase 240V class	0.4 to 4.0kW
3-phase 500V class	0.75 to 4.0kW

- To set makers -

Please see to it that this manual is supplied to the inverter's end user, along with the instruction manual E6581158.

■ Safety precautions

Before reading this manual, please read the following instructions in addition to “I. Safety Precautions,” of the instruction manual E6581158.

■ General Operation**Mandatory**

- Circuit boards are exposed when the front cover is removed. So do not detach the front cover when the inverter is energized or within 10 minutes after power is turned off. Doing so could result in electric shock.

■ Transportation**Mandatory**

- When handling the inverter unit, hold it by both the sides firmly. If you hold it by the fins at the upper and lower parts, you could get injured.

■ Exterior Features

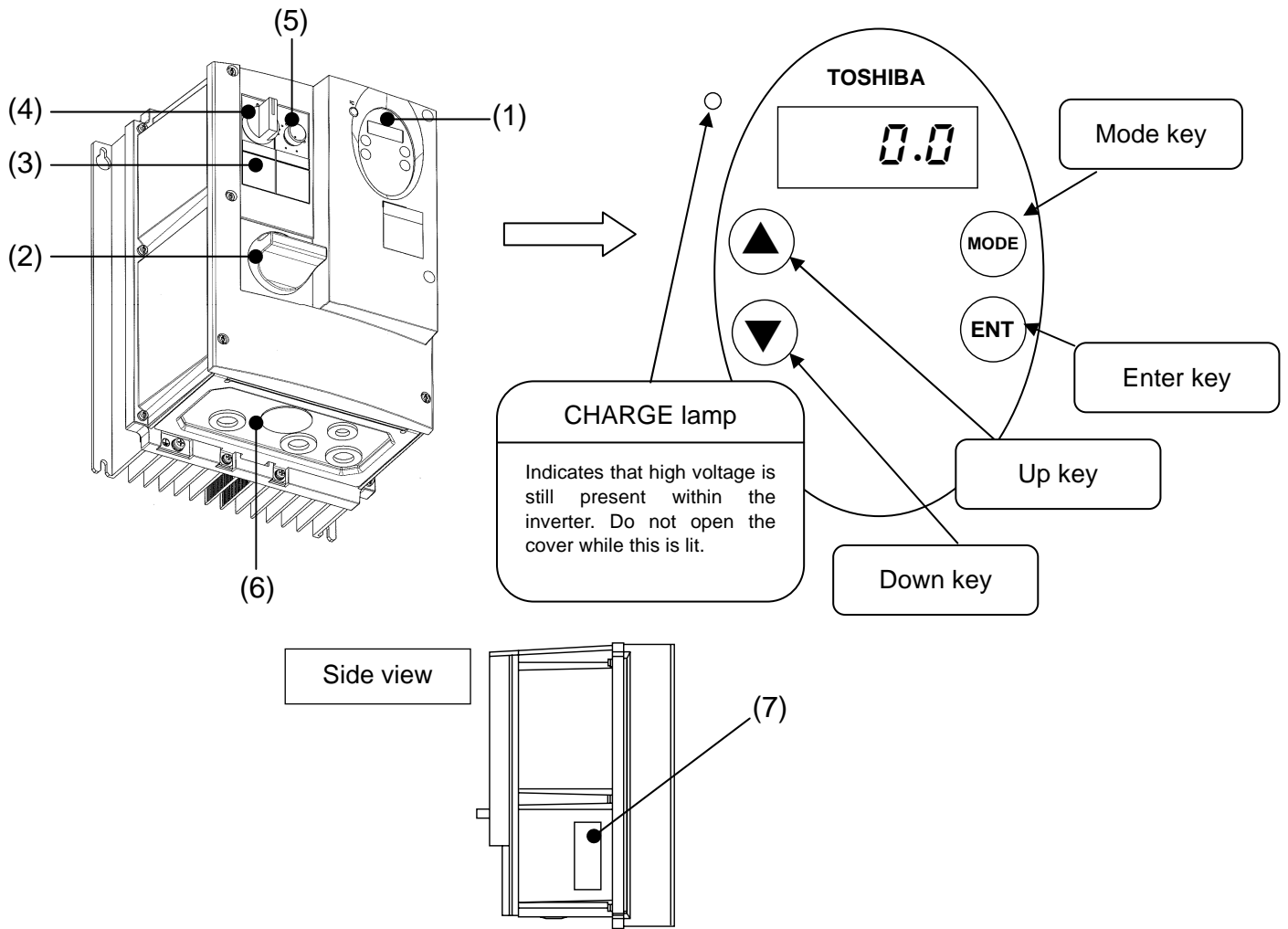

No.	Devices	Remarks
(1)	Operation panel	Equipped with ▲, ▼, MODE and ENT keys used to set parameters, a 7-segment LED and a CHARGE lamp.(The inverter does not have a RUN key, a STOP key and a potentiometer control, which are provided for VF-S11 standard series inverters.)
(2)	Manual power ON-OFF switch	Used to turn on and off power manually. Note 1:
(3)	Slots (x 2) reserved for optional devices	Slots for optional contact input switches. Note 2:
(4)	Operation ON-OFF rotary switch	Used to start and stop the inverter.
(5)	Potentiometer for frequency setting	Used to set the operation frequency of the inverter.
(6)	Wiring port plate	Steel plate with wiring portsThe effects of noise can be reduced to some degree by fixing shielded parts of cables with cable grounds or similar devices. See page 7.
(7)	Name plate	Label on which the ratings of the inverter unit is printed.

Note 1: The switch has the function of tripping (overcurrent tripping). If the switch is in the Trip position, inspect the inverter before turning back on the power switch, because the inverter itself may be faulty.

Note 2: Recommended contact input switches: Harmony series (XB5 series)

■ Main circuit and control circuit terminal boards

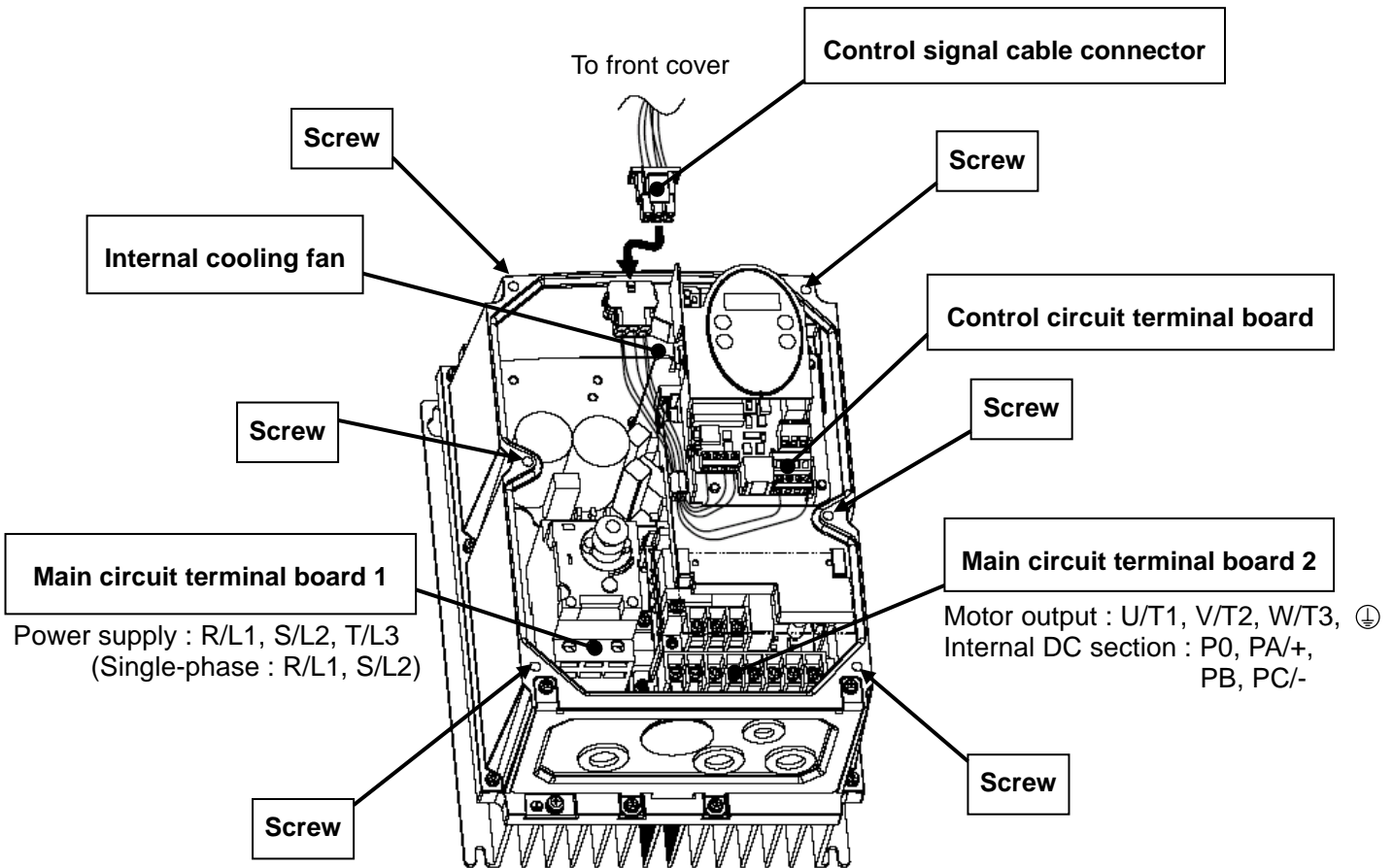

How to remove the front cover

1. Shut off the supply of electricity from the main power supply, and turn the manual power ON-OFF switch to the OFF position.
2. Ten minutes or more after turning off power, check to be sure that the CHARGE lamp is not lit.
3. Remove the 6 screws* (indicated by the arrows in the figure) around the front cover.
(* 4 screws for single/three-phase 240V-0.75kW models and smaller)
4. Pull the front cover slowly toward you to remove it and detach the control signal cable connector.

How to attach the front cover

1. Attach the control signal cable connector.
2. Attach the front cover.
3. Set and tighten the 6 screws* (indicated by the arrows in the figure) around the front cover.
(* 4 screws for single/three-phase 240V-0.75kW models and smaller)

Caution: Attach the front cover securely.

Or else it does not serve as a protector compliant with IP54.

On top of that, it may become impossible to operate the keys on the operation panel.

About the built-in cooling fan

The inverter has a built-in cooling fan. The cooling fan has a useful life of approximately 30,000 hours (2 to 3 years when operated continuously), so it needs to be replaced periodically.

(Single/three-phase 240V-0.75kW models and smaller are not equipped with cooling fans.)

If the cooling fan does not operate normally, the temperatures of the internal electrical components will rise high, and as a result their lives will be shortened. So inspect it periodically.

About the useful life of the manual power ON-OFF switch

The manual power ON-OFF switch has a useful life of approximately 5 years (if operated 12 hours per day at an average yearly ambient temperature of 30°C), so it needs to be replaced periodically.

■Wiring diagram

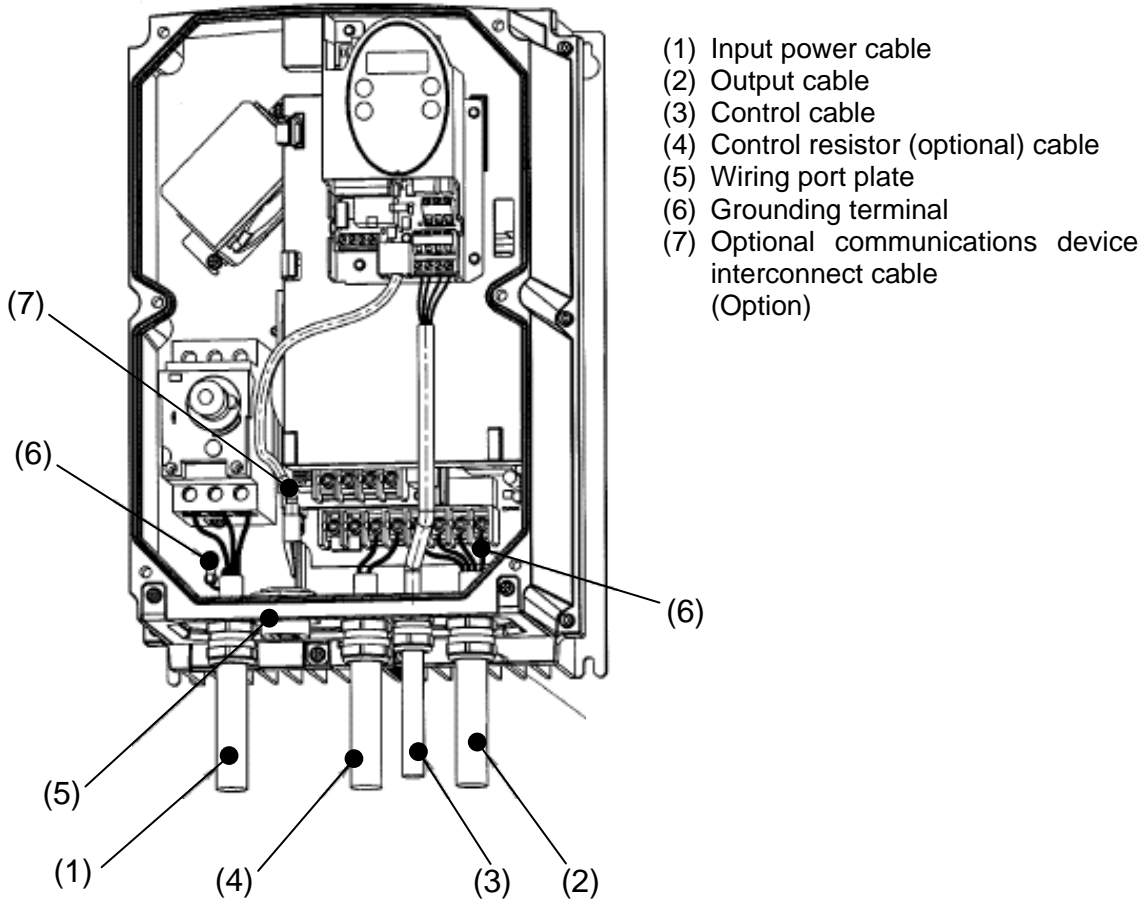

Cautions

- Circuit boards are exposed when the front cover is removed. Since high voltages are applied to some parts of the circuit board, read Section 2.1, "Cautions on wiring," of the instruction manual E6581158 carefully before wiring.
 When connecting cables, take care not to damage the circuit board with a screwdriver or a similar tool.
- To connect the power cable (to the manual power ON-OFF switch), torque the terminal screw to 1.7N·m (recommended). (M4 screw)
- Never turn on the power ON-OFF switch before attaching the front cover.
 Or you could get a shock.

The main circuit terminal board (input power cable) has terminals of a cable pinch type. Before connecting a cable, strip off its sheath to a length of 10mm or so. Torque: 1.7N·m

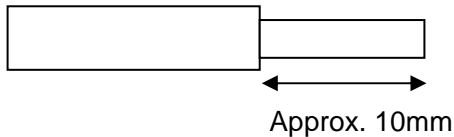

■ Diagram of cables connected at the factory

< WN type : Sink logic >

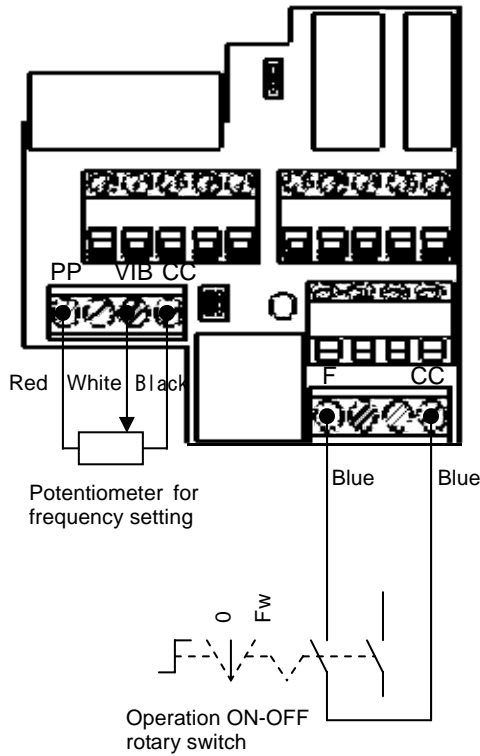

< WP type : Source logic >

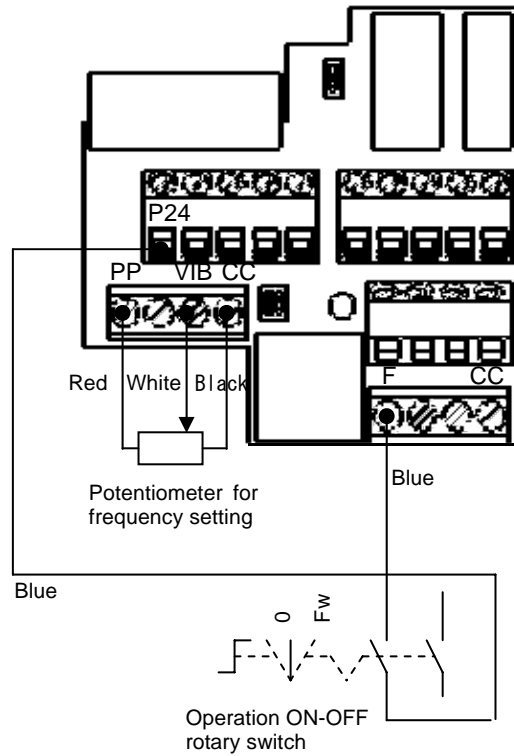

Note: The colors indicated in the above figure refer to the colors of cables.

■ Installation environment

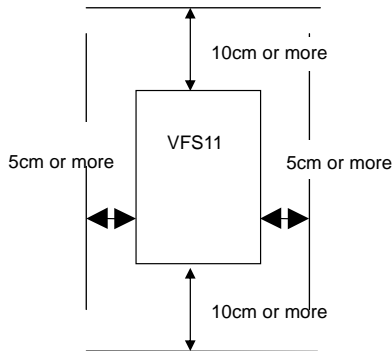

- Operate in areas where ambient temperature ranges from -10°C to +40°C.
- Install the inverter in a well-ventilated place and mount it on a flat metal plate in portrait orientation. Install the inverter so that it is not inclined more than $\pm 10^\circ$ from the vertical.
- Leave a space of 10cm or more on the upper and lower sides of the inverter, and a space of 5cm or more on each side.
- The inverter has a built-in cooling fan. The cooling fan has a useful life of approximately 30,000 hours (2 to 3 years when operated continuously), so it needs to be replaced periodically. The inverter has a built-in cooling fan. (Single/three-phase 240V-0.75kW models and smaller are not equipped with cooling fans.)

If the cooling fan does not operate normally, the temperatures of the internal electrical components will rise high, and as a result their lives will be shortened.

So inspect it periodically.

■ Outside dimensions

Voltage class	Applicable Motor (kW)	Inverter type	Outside dimensions (mm)						Cable port
			W	H	D	W1	H1	D1	
1-phase 240V	0.2	VFS11S-2002PLE	210	240	177	192	218	14	φ19×3 φ21×1
	0.4	VFS11S-2004PLE							
	0.75	VFS11S-2007PLE							
	1.5	VFS11S-2015PLE	215	297	206	197	277	14	
	2.2	VFS11S-2022PLE	230	340	222	212	320	14	
3-phase 240V	0.4	VFS11-2004PME	210	240	177	192	218	14	φ19×3 φ21×1
	0.75	VFS11-2007PME							
	1.5	VFS11-2015PME	215	297	206	197	277	14	
	2.2	VFS11-2022PME							
	4.0	VFS11-2037PME							
3-phase 500V	0.75	VFS11-4007PLE	215	297	206	197	277	14	φ19×1 φ23×3
	1.5	VFS11-4015PLE							
	2.2	VFS11-4022PLE	230	340	222	212	320	14	
	4.0	VFS11-4037PLE							

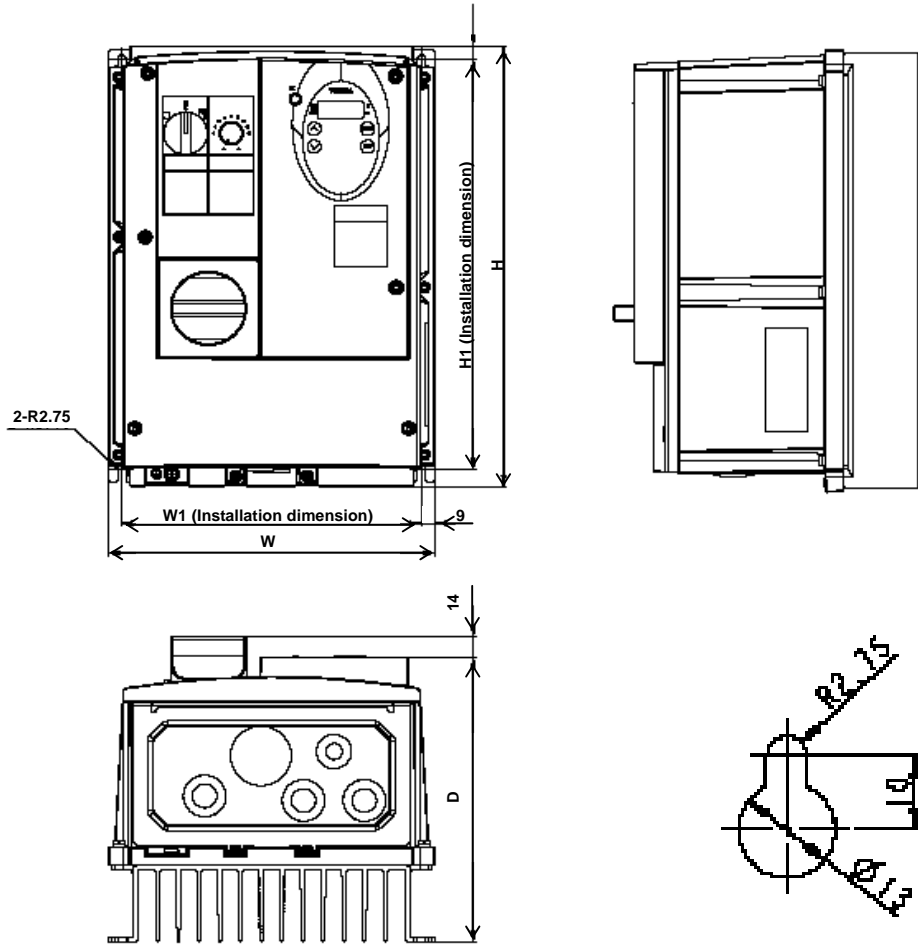

■ Specifications

Item		Specification						
Voltage class		1-phase 240V class/3-phase 240V class/3-phase 500V class						
Applicable motor (kW)		0.2	0.4	0.75	1.5	2.2	4.0	
Model	Voltage class	VFS11S-/VFS11-						
	Model number							
	1-phase 240V class	VFS11S-	2002PLE	2004PLE	2007PLE	2015PLE	2022PLE	-
	3-phase 240V class	VFS11-	-	2004PME	2007PME	2015PME	2022PME	2037PME
3-phase 500V class	VFS11-	-	-	4007PLE	4015PLE	4022PLE	4037PLE	
Rating	Capacity (kVA)	Note 1:	0.6	1.3	1.8	3.0 /3.0 /3.1	4.2	6.7 /7.2
	Output current (A)	1-phase 240V	1.5 (1.5)	3.3 (3.3)	4.8 (4.4)	8.0 (7.9)	11.0 (10.0)	-
		3-phase 240V	-	3.3 (3.3)	4.8 (4.4)	8.0 (7.9)	11.0 (10.0)	17.5 (16.4)
		3-phase 500V	-	-	2.3 (2.1)	4.1 (3.7)	5.5 (5.0)	9.5 (8.6)
Output voltage	Note 3:	240V class: 3-phase 200 to 240V, 500V class: 3-phase 380 to 500V						
Overload current rating		150%-1min., 200%-0.5 sec. (50%-reduction value)						
Power supply	Voltage-frequency	240V class: 1-phase/3-phase 200 to 240V-50/60Hz, 500V class: 3-phase 380 to 500V-50/60Hz						
	Allowable fluctuation	Voltage±10%, -15% Note 4:, Frequency±5%						
Protective method		Totally enclosed type (JEM1030) compliant with IP54/possible to bring into compliance with IP55 Note 5:						
Cooling method		Self-cooled (with a built-in cooling fan. 1-phase/3-phase 240V-0.75kW or smaller: Cooling fan not provided)						
Color		Munsel 5Y-8/0.5						
Built-in filter		1-phase & 500V class: High-attenuation EMI filter, 3-phase 240V class: Standard filter						
Environments	Use environments	Indoor type. Altitude: Not more than 1000m. Place free from corrosive and explosive gases						
	Ambient temperature	-10 to +40°C						
	Storage temperature	-25 to +70°C						
	Relative humidity	20 to 93%						
	Vibration	5.9m/s ² or less (10 to 55Hz)						

Note 1: Capacity is calculated at 220V for the 240V models and at 440V for the 500V models.

Note 2: Indicates rated output current setting when the PWM carrier frequency (parameter F300) is 4kHz or less. The values between parentheses refer to output currents at PWM carrier frequencies of over 4kHz. They need to be reduced further at frequencies over 12kHz (If a motor cable over 30m in length is used, it is necessary to reduce them more. This means that the lives of the internal components will be shortened). When the input power voltage of the 500V class model exceeds 480V, it is necessary to further reduce the setting. The default setting of the PWM carrier frequency is 12kHz.

Note 3: The maximum output voltage is equal to the input supply voltage.

Note 4: ±10% when the inverter is operated continuously (under a load of 100%).

Note 5: IP54-compliant structures refer to structures that protect the contents from dust and harmful effects of water that drops from every direction. The inverter can be brought into compliance with IP55 specifications by making the wiring port watertight.

(IP55-compliant structures refer to structures that protect the contents from dust and harmful effects of water that comes in a jet from every direction.)

To bring the inverter into compliance with IP-55, use PG screw type cable grounds. Among cable grounds available are skin-top grounds manufactured by LAPP (Germany).

When using this type of grounds, use them in combination with lock nuts specified below.

Cable port	Cable ground	Cable ground(EMC-compliant)	Lock nut
φ19 hole	MS11	MS-SC11	SM-11
φ21 hole	MS13.5	MS-SC13.5	SM-13.5
φ23 hole	MS16	MS-SC16	SM16

Note 6: For control specifications, parameters and functions, refer to the instruction manual E6581158.

Note 7: The factory default settings of the following parameters are different from those of the VFS-11 standard type.

Title	Function	Standard VF-S11	Totally enclosed type VF-S11
<i>F00d</i>	Command mode selection	1	0
<i>F00d</i>	Frequency setting mode selection	0	2

Note 8: The inverter has a built-in cooling fan. The cooling fan has a useful life of approximately 30,000 hours (2 to 3 years when operated continuously), so it needs to be replaced periodically.

(Single/three-phase 240V-0.75kW models and smaller are not equipped with cooling fans.)

If the cooling fan does not operate normally, the temperatures of the internal electrical components will rise high, and as a result their lives will be shortened. So inspect it periodically.

Note 9: The manual power ON-OFF switch has a useful life of approximately 5 years (if operated 12 hours per day at an average yearly ambient temperature of 30°C), so it needs to be replaced periodically.