

# TOSHIBA

# Transistor Inverter

You thought they were all the same...

### Standard specifications VF-S11

Item		Specification										
Input voltage class		1-phase 240V class/3-phase 240V class/3-phase 500V class										
Applicable motor (kW)		0.2	0.4	0.55	0.75	1.5	2.2	3.7	5.5	7.5	11	15
Machine type	VFS11S/VFS11 Model	VFS11S/VFS11										
	1φ-240V class	VFS11S-2002PL	2004PL	—	2007PL	2015PL	2022PL	—	—	—	—	—
	3φ-240V class	VFS11S-2002PM	2004PM	2005PM	2007PM	2015PM	2022PM	2037PM	2055PM	2075PM	2110PM	2150PM
Rating	Capacity (kVA)	0.6	1.3/1.1	1.4	1.8	3.1	4.2	6.7/7.2	10/11	13	21	25
	Output current(A)	1φ-240V class	1.5	3.3	—	4.8	8.0	11.0	—	—	—	—
		3φ-240V class	1.5	3.3	3.7	4.8	8.0	11.0	17.5	27.5	33	54
Power supply	Voltage-frequency	240V class: 200V to 240V - 50/60Hz, 500V class: 3-phase 380 to 500V - 50/60Hz										
	Allowable fluctuation	Voltage +10%, -15% (±10% when the inverter is used continuously (load of 100%))										
Rated output voltage		Adjustable within a range of the corrected supply voltage 50 to 660V (Unadjustable to any voltage higher than the input voltage).										
Output frequency range		0.5 to 500.0Hz (default setting 0.5 to 80.0Hz)										
Voltage/frequency characteristics		V/f constant, variable torque, automatic torque boost, vector control, automatic energy conservation, dynamic energy conservation control, PM motor control, auto-tuning function										
Overload current rating		60 seconds at 150%, 0.5 seconds at 200% (Anti-time limit characteristic)										
Dynamic braking		With a built-in dynamic braking circuit, external braking resistor available (option)										
Control terminal panel		Removable (possible to internalize various transmission option circuit boards after removal)										
Input/output terminal logical switching		Sink logic (minus common)/source logic (plus common) can be switched with a switch										
Principal functions		PID control, acceleration/deceleration time (three patterns), S acceleration/deceleration time (controllable), forced deceleration, automatic adjustable speed, automatic torque boost, programmable input terminal (8 terminals with 65 functions), programmable output terminal (3 terminals with 58 functions can be divided in two), voltage/current analog output, pulse string output, lifespan warning monitor/output, 15 speed levels, detailed monitor display at trip, selectable units, selectable steps, droop, overwrite, regenerative power ride-through, auto-restart, history, customer parameter memory, and others										
Options		DIN rail kit (1.5kW or less), EMC foot-mounted filter, EMI noise reduction plate, NEMA Type 1 kit, internal RS485 communication circuit board, various communication circuit boards, an assortment of other shared options for TOSHIBA inverters										
Ambient temperature/relative humidity		-10 to 60°C (Above 40°C: Remove the protective seal from the top/20 to 93% free from condensation and vapor)										
Installation		Side by side installation (contiguous installation) possible										
Protective method		IP20 enclosed type (JEM1030)										
Cooling method		Self cooling (500V class has forced air cooling)					Forced air cooling					
Built-in filter		1-phase 240V class, 500V class: High attenuation EMI filter, 3-phase 240V class: Standard filter										

Note: The L on the end of the model number indicates a built-in high-attenuation EMI noise filter, and the M indicates the standard built-in EMI noise filter.

### Exterior dimensions and weight

Input voltage class	Applicable motor (kW)	Inverter model	Dimensions (mm)			Approx. weight (kg)
			Width	Height	Depth	
1-phase 240V	0.2	VFS11S-2002PL	72	130	130	1.0
	0.4	VFS11S-2004PL			140	1.0
	0.75	VFS11S-2007PL	140	170	150	2.2
	1.5	VFS11S-2015PL	105	130	150	1.4
3-phase 240V	0.2	VFS11-2002PM	72	130	120	0.9
	0.4	VFS11-2004PM			130	0.9
	0.75	VFS11-2007PM	105	130	130	1.1
	1.5	VFS11-2015PM			150	1.2
	2.2	VFS11-2022PM	140	170	150	1.3
	3.7	VFS11-2037PM			170	2.2
	5.5	VFS11-2055PM	180	220	170	4.8
	7.5	VFS11-2075PM	245	310	190	4.9
	11	VFS11-2110PM			9.3	
	15	VFS11-2150PM	9.6			
3-phase 500V	0.4	VFS11-4004PL	105	130	150	1.4
	0.75	VFS11-4007PL			150	1.5
	1.5	VFS11-4015PL	140	170	150	1.5
	2.2	VFS11-4022PL			2.3	
	3.7	VFS11-4037PL	150	2.5		
	5.5	VFS11-4055PL	180	220	170	5.0
	7.5	VFS11-4075PL	5.1			
11	VFS11-4110PL	9.6				
15	VFS11-4150PL	245	310	190	9.6	

### Standard connection diagram: Sink logic

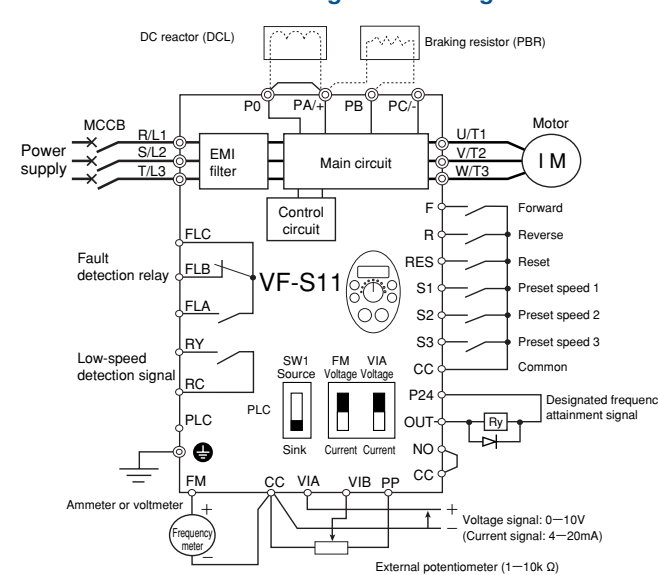

To users of our inverters : Our inverters are designed to control the speeds of three-phase induction motors for general industry.

### Precautions

- \* Read the instruction manual before installing or operating the inverter unit and store it in a safe place for reference.
- \* When using our inverters for equipment such as nuclear power control equipment, aviation and space flight control equipment, traffic equipment, and safety equipment, and there is a risk that any failure or malfunction of the inverter could directly endanger human life or cause injury, please contact our headquarters, branch, or office printed on the front and back covers of this catalogue. Such applications must be studied carefully.
- \* When using our inverters for critical equipment, even though the inverters are manufactured under strict quality control always fit your equipment with safety devices to prevent serious accident or loss should the inverter fail (such as failure to issue an inverter trouble signal).
- \* Do not use our inverters for any load other than three-phase induction motors.
- \* None of Toshiba, its subsidiaries, affiliates or agents, shall be liable for any physical damages, including, without limitation, malfunction, anomaly, breakdown or any other problem that may occur to any apparatus in which the Toshiba inverter is incorporated or to any equipment that is used in combination with the Toshiba inverter. Nor shall Toshiba, its subsidiaries, affiliates or agents be liable for any compensatory damages resulting from such utilization, including compensation for special, indirect, incidental, consequential, punitive or exemplary damages, or for loss of profit, income or data, even if the user has been advised or apprised of the likelihood of the occurrence of such loss or damages.

For further information, please contact your nearest Toshiba Representative or International Operations-Producer Goods. The information in this brochure is subject to change without notice.

In Touch with Tomorrow  
**TOSHIBA**

TOSHIBA CORPORATION  
INDUSTRIAL AND POWER SYSTEMS & SERVICES COMPANY

Control & Measurement Department  
1-1, Shibaura 1-chome, Minato-ku,  
Tokyo 105-8001, Japan  
Tel.: (03)3457-4911 Fax.: (03)5444-9268

03-11 (AB)8691 (AB)

Printed in Japan

New Global Standard Inverter TOSVERT™

# VF-S11

1-phase 240V 0.2kW to 2.2kW  
3-phase 240V 0.2kW to 15kW  
3-phase 500V 0.4kW to 15kW



## Our brilliance has a reason.

It's hard to find a good egg by just looking at it.

The same can be said for inverters.

They all look the same, but actually you can have superior performance.

VF-S11

As a result of aiming a little higher, our eggs have a little more sparkle.



New Global Standard Inverter **TOSVERT™**

# VF-S11

**Built-in EMI noise filter**

**Introducing the world's top class compact inverter**

## 1.High Torque

Initial torque surpasses 1Hz-200%\* at start up instantly from low speed. Smooth operation in regeneration area as well as motoring area is possible through Toshiba's very own power vector control. Moreover, you can make settings in a single step by using the automatic torque boost function with auto tuning accomplished at the same time. Equipped with an energy saving mode, application reach a higher level of efficiency.

\* When running a standard Toshiba 4-pole motor. (Depends on the voltage and range.)

## 2.Compact

Save space with its super compact design that has greatly reduced dimensions. Plus, you can install multiple units side by side for high-density facilities. Moreover, for such a compact model, it has a surprisingly high level of functionality. Its ease-of-use makes it a top class inverter.

\*Refer to the specifications on the reverse.

■Side by side installation



■Removable terminal board

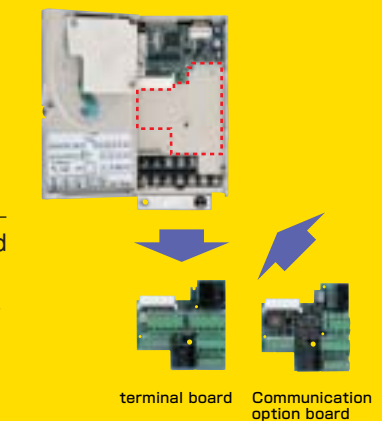

## 3.Removable terminal board

It is the first in its class with a removable control terminal. Wiring and ease of maintenance are improved exceptionally. The control terminal circuit board can be removed leaving space for an internally mounted communications option board.

## 4.Built-in EMI Noise Filter

Environmental considerations are also the very best in its class. Single-phase and 500V devices are equipped with a high-attenuation EMI noise filter greatly reducing the RFI noise generated by the inverter.

For 1-ph 240V, and 3-ph 500V models : EN55011 Class A Group 1(Max.5m\*) - standard built-in, Class B Group 1(Max.20m\*) - external noise filter option.

For 3-ph 240V : EN55011 Class A Group 1(Max.5m\*) - standard, Class B Group 1(Max.1m\*) - external noise filter option.

\* Length of motor connecting cable.

## 5.Easy maintenance

A warning signal is output to the panel monitor when the electrolytic capacitors on the main circuit, the cooling fan and the control board have been reached the replacement period. A valuable indicator which can be used as a maintenance guideline. The cooling fan can be replaced easily, and the automatic on/off function provides extended machine life. On top of that, the main circuit capacitors are designed with a 10year lifetime\*making this a long-life inverter. It can be used in an ambient temperature up to 60 °C for leading environmental resistance. (Minimum reduction of current required)

\* Ambient temperature: average yearly temperature of 40 °C. Output voltage: Operating 24 hours per day for 365 days at 80% of the current rating for Toshiba's 4-pole motor.

## 6.Extended power range

Wide range of powers up to 15kW for this class of inverter.

■Capacity range

Voltage class	Applicable motor (kW)										
	0.2	0.4	0.55	0.75	1.5	2.2	3.7	5.5	7.5	11	15
1-phase 240V	[Bar chart showing applicable motor range from 0.2 to 15 kW]										
3-phase 240V	[Bar chart showing applicable motor range from 0.2 to 15 kW]										
3-phase 500V	[Bar chart showing applicable motor range from 0.2 to 15 kW]										

\* 0.55kW is 3-phase 240V class only.

