

TH450A-CRB
TH550A-CRB
THP550-CRB/TS3000
Industrial Robot 

INSTRUCTION MANUAL

CLEAN TYPE
INDUSTRIAL ROBOT SPECIFICATIONS

Notice

- Make sure that this instruction manual is delivered to the final user of Toshiba Machine's industrial robot.
- Before operating the industrial robot, read through and completely understand this manual.
- After reading through this manual, keep it nearby for future reference.

May 2010

TOSHIBA MACHINE CO., LTD.

NUMAZU, JAPAN

Copyright 2010 by Toshiba Machine Co., Ltd.
All rights reserved.

No part of this document may be reproduced in any form without obtaining prior written permission from Toshiba Machine Co., Ltd.

The information contained in this manual is subject to change without prior notice to effect improvements.

Preface

This manual describes the specifications of the TH-A and THP series clean type industrial robots.



This manual is essential to keep the robot performance for a long time, to prevent failures and to assure safety. Be sure to look through this manual and set up a maintenance program before actually starting the robot.

Precautions on Safety

Important information on the robot and controller is noted in the instruction manual to prevent injury to the user and persons nearby, prevent damage to assets and to ensure correct use.

Make sure that the following details (indications and symbols) are well understood before reading this manual. Always observe the information that is noted.



[Explanation of indications]

Indication	Meaning of indication
 DANGER	This means that "incorrect handling will imminently lead to fatalities or major injuries".
 WARNING	This means that "incorrect handling may lead to fatalities or serious injuries."
 CAUTION	This means that "incorrect handling may lead to personal injuries *1) or physical damage *2)".

*1) Injuries refer to injuries, burns and electric shocks, etc., which do not require hospitalization or long term treatment.



*2) Physical damage refers to major damage due to destruction of assets or resources.



[Explanation of symbols]

Symbol	Meaning of symbol
	This means that the action is prohibited (must not be done). Details of the actions actually prohibited are indicated with pictures or words in or near the symbol.
	This means that the action is mandatory (must be done). Details of the actions that must be done are indicated with pictures or words in or near the symbol.
	This means danger and caution. Details of the actual danger and caution are indicated with pictures or words in or near the symbol.

[Maintenance and inspection]

Be sure to observe the following items to use this product safely.

 DANGER	
 Prohibited	<ul style="list-style-type: none"> • DO NOT incinerate, disassemble or charge the batteries. Otherwise, they may rupture.
 Mandatory	<ul style="list-style-type: none"> • Be sure to turn off the main power switch of the controller before starting inspection or maintenance. • Batteries should be disposed of according to the user's in-house regulations.

 CAUTION	
 Disassembly prohibited	<ul style="list-style-type: none">• The user must NEVER replace or modify parts other than those described in the instruction manual. Otherwise, the performance may deteriorate or faults or accidents will be caused.
 Mandatory	<ul style="list-style-type: none">• Always use the Toshiba Machine's designated spare parts when replacing the parts.• Maintenance and inspection should be performed regularly. Otherwise, the system may malfunction or accidents will be caused.

This manual is comprised of the following six (6) sections:

Section 1 Specifications

This section describes the basic specifications and names of respective parts of the clean type industrial robot.

Section 2 Transportation

This section describes how to remove the clean type robot from its box and how to transport it to the installation site.

Section 3 Installation

This section discusses the clean type robot installation environment, space requirements, and how to install the robot.

Section 4 Tool Interface

This section discusses how to connect the cables and pipelines for the tool of the clean type robot.

Section 5 Maintenance

This section describes the structure of the clean type robot and all items required for the maintenance and inspection of the same robot.

Section 6 Replacement Parts for Maintenance

This section explains the replacement parts for the maintenance.

Table of Contents

	Page
1. Specifications	8
1.1 Name of Each Part	8
1.2 Outer Dimensions	9
1.3 Specifications Table.....	15
2. Transportation	19
2.1 Unpacking and Transport	19
2.2 Mass and Outer Dimensions	19
2.3 Cautions on Transporting the Robot	21
3. Installation	23
3.1 Installation Environment	23
3.2 Air Suction Volume	24
3.3 Coordinate System	25
3.4 Installing the Robot.....	27
4. Tool Interface.....	28
4.1 Tool Air Piping	28
5. Maintenance	30
5.1 Items for Maintenance and Inspection	30
5.1.1 Check for Bellows.....	31
5.1.2 Replacement of Bellows.....	31
5.1.3 Filling Grease to Ball Screw Spline Unit	31
5.2 Layout of Robot Components	32
5.3 Mounting and Dismounting Covers.....	34
5.3.1 Base Cover	34
5.3.2 Arm 1 Covers	35
5.3.3 Arm 2 Cover	37
5.4 Replacing Bellows	38
5.4.1 Replacement Procedures for Bellows (Lower)	38
5.4.2 Replacement Procedures for Bellows (Upper)	39
6. Replacement Parts for Maintenance.....	41
6.1 Replacement Parts List for Maintenance	41

1. Specifications

1.1 Name of Each Part

The names of respective parts of the clean type robot are shown in Fig. 1.1 below.

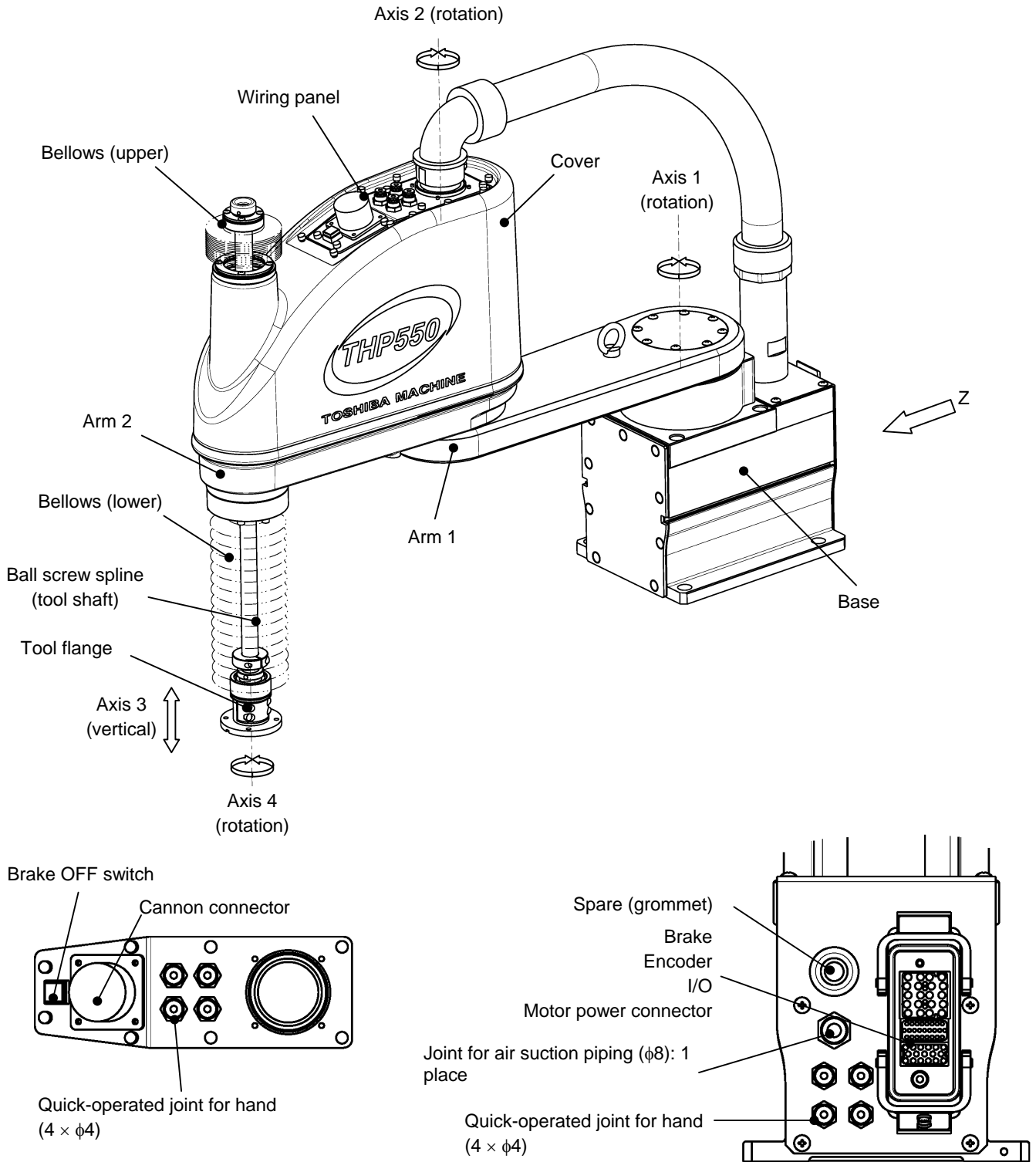

Fig. 1.1 Name of each part

1.2 Outer Dimensions

Fig. 1.2 to Fig. 1.4 show the outer dimensions of the robot and Fig. 1.5 to Fig. 1.7 show the operating range of the robot.

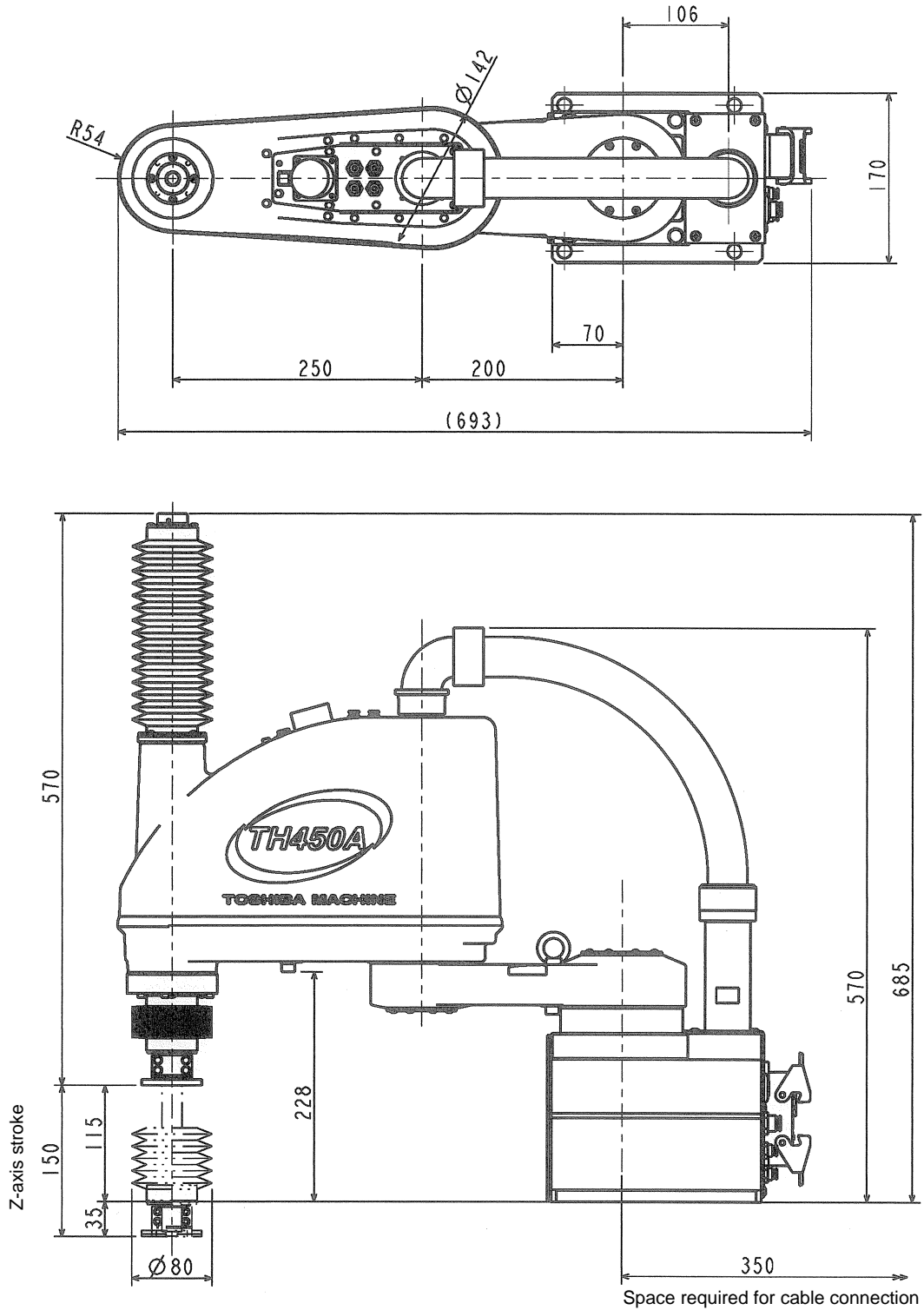

Fig. 1.2 Outer dimensions of the robot (TH450A-CRB)

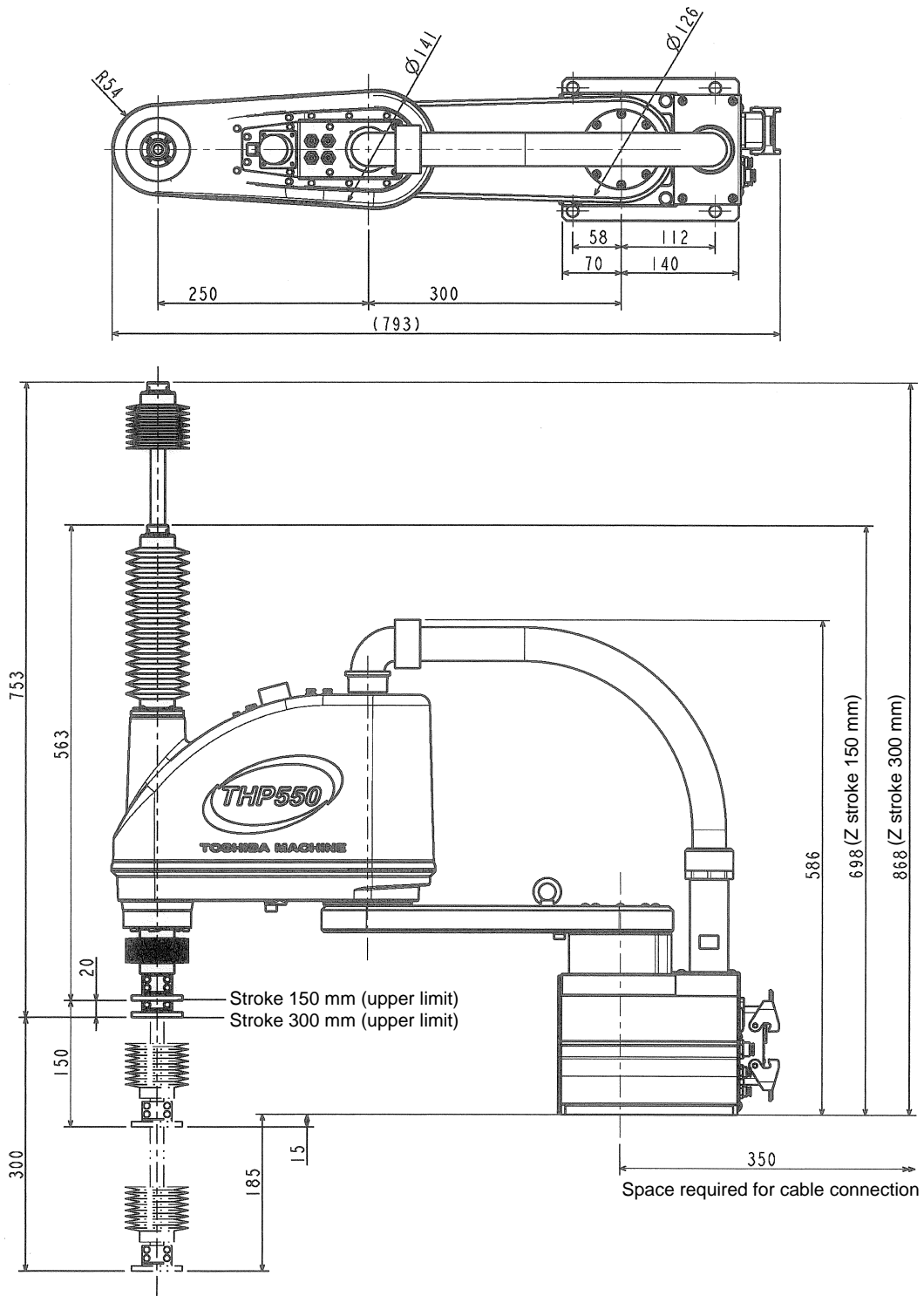

Fig. 1.4 Outer dimensions of the robot (THP550-CRB)

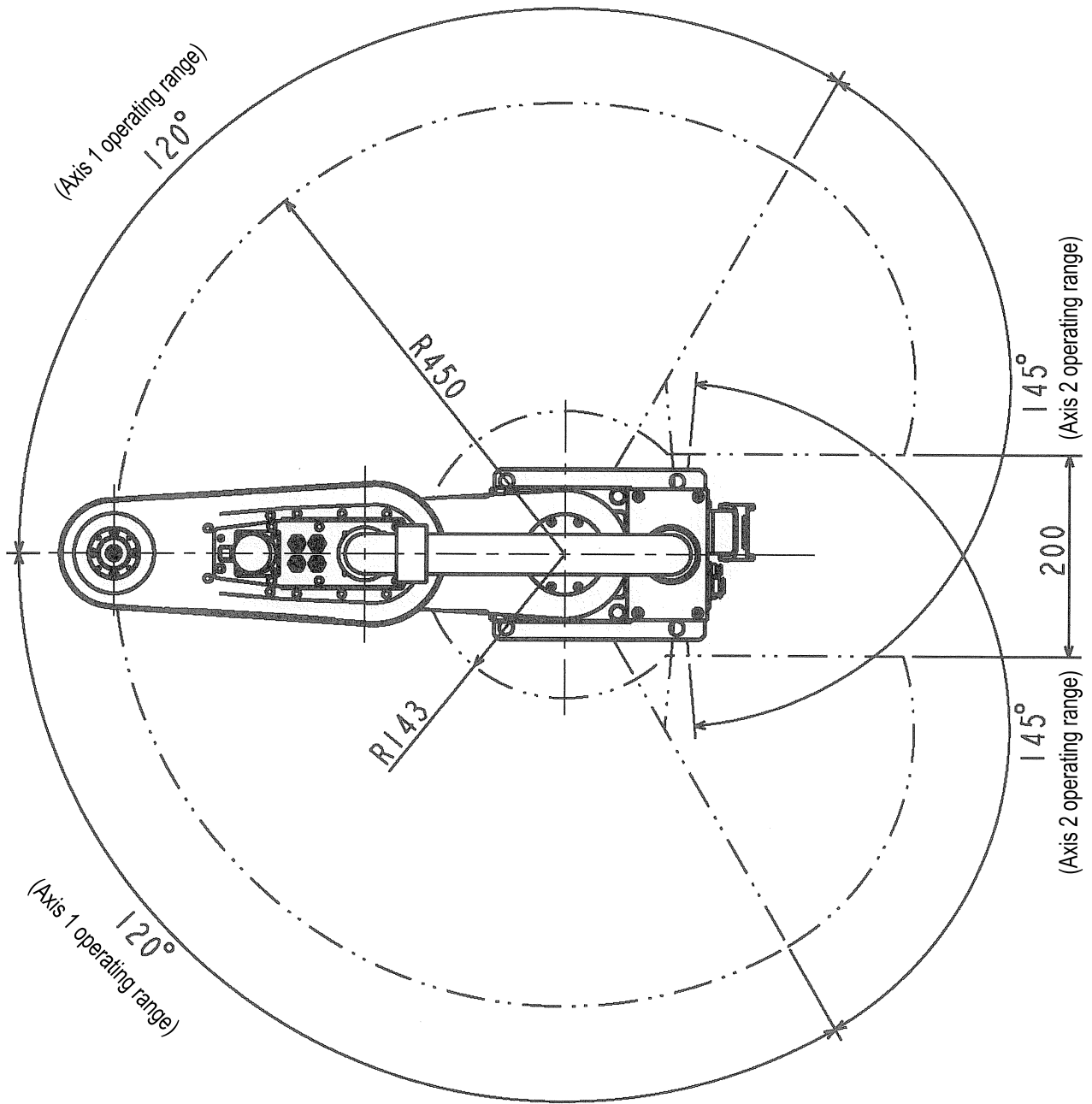

Fig. 1.5 Operating range of the robot (TH450A-CRB)

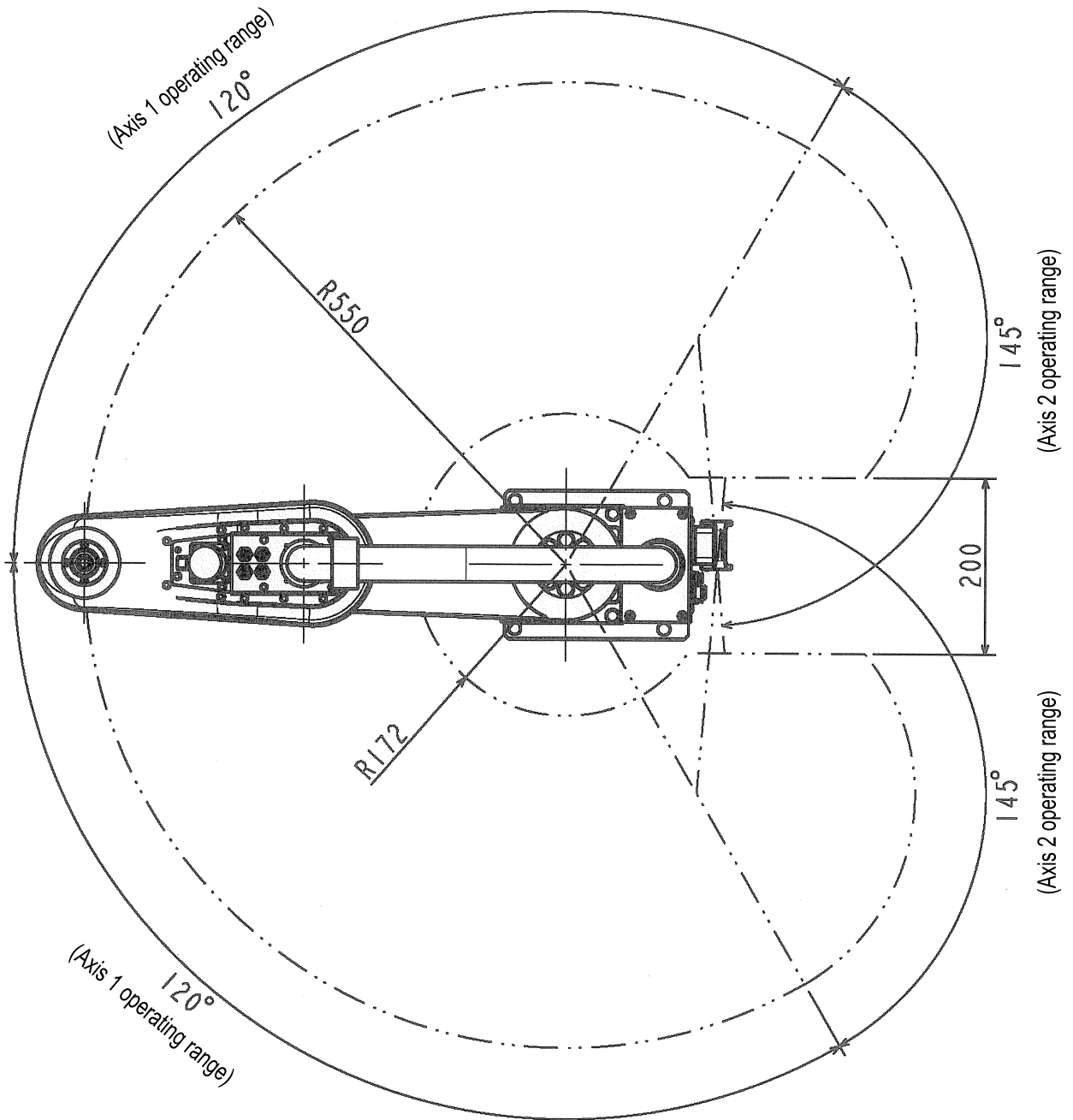

Fig. 1.6 Operating range of the robot (TH550A-CRB)

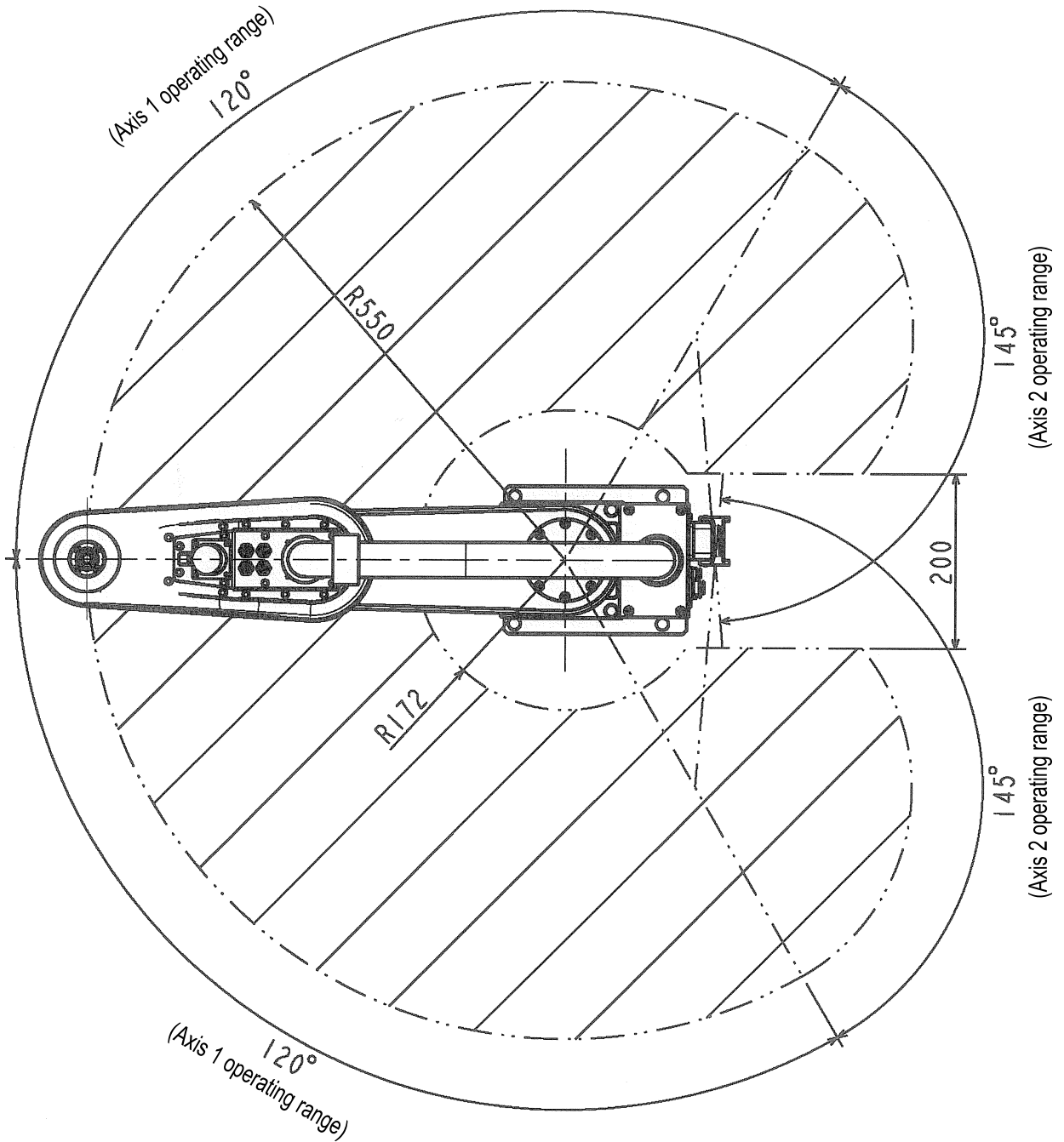

Fig. 1.7 Operating range of the robot (THP550-CRB)

1.3 Specifications Table

Item		Specifications	
Structure		Horizontal multi-joint type SCARA robot	
Model		TH450A-CRB	TH550A-CRB
Applicable controller		TS3000 (*1)	
Mass of robot body		28 kg	29 kg
No. of controlled axes		Four (4)	
Arm length		450 mm (200 + 250)	550 mm (300 + 250)
Motor capacity	Axis 1	1,000 (W)	
	Axis 2	400 (W)	
	Axis 3	200 (W)	
	Axis 4	200 (W)	
Operating range	Axis 1	±120 (deg)	
	Axis 2	±145 (deg)	
	Axis 3	150 (mm) [Option: 300 (mm)]	
	Axis 4	±360 (deg)	
Maximum speed (*2)	Axis 1	600 (deg/s)	375 (deg/s)
	Axis 2	600 (deg/s)	
	Axis 3	2,000 (mm/s)	
	Axis 4	2,000 (deg/s)	
	Composite speed of axes 1 and 2	7.3 (m/s)	6.21 (m/s)
Rated payload mass		2 (kg)	
Maximum payload mass		5 (kg)	
Permissible load inertia (*2)		0.06 (kg·m ²)	
Repeatability (*3)	X, Y	±0.01 (mm)	
	Z	±0.01 (mm)	
	C	±0.005 (deg)	
Cycle time (*4) (When payload mass is 2 kg)		0.30 (sec)	
Drive system		By means of AC servo motors	
Position detection method		Absolute	

Item	Specifications
Cleanness level (*5)	Ten (10) or less dust particles of 0.1 μm or over in diameter, which exist in 1 cft (28,317 cm^3) of a sample area. Equivalent to clean class 3 defined by ISO
Air suction volume	60 normal liters/min

- *1: The structure of the robot controller is not of a clean type.
- *2: When the mass of load exceeds 2 kg, or when the gravity center position of load is away from the axis 4 center position, both the speed and acceleration should be reduced, using the PAYLOAD command.
- *3: The ambient temperature is predetermined at 20°C.
- *4: Shuttle time for rough positioning in horizontal direction of 300 mm and vertical direction of 25 mm.
- *5: When the air suction volume is 60 normal liters/min, down flowrate in the clean room is 0.4 m/s or over.

[THP550-CRB]

Item		Specifications
Structure		Horizontal multi-joint type SCARA robot
Model		THP550-CRB
Applicable controller		TS3000 (*1)
Mass of robot body		27 kg
No. of controlled axes		4
Arm length		550 mm (300 + 250)
Motor capacity	Axis 1	1000 (W)
	Axis 2	400 (W)
	Axis 3	200 (W)
	Axis 4	100 (W)
Operating range	Axis 1	±120 (deg)
	Axis 2	±145 (deg)
	Axis 3	150 (mm) [Option: 300 (mm)]
	Axis 4	±360 (deg)
Maximum speed (*2)	Axis 1	375 (deg/s)
	Axis 2	600 (deg/s)
	Axis 3	2,000 (mm/s)
	Axis 4	2,000 (deg/s)
	Composite speed of axes 1 and 2	6.21 (m/s)
Rated payload mass		1 (kg)
Maximum payload mass		2 (kg)
Permissible load inertia (*2)		0.01 (kg·m ²)
Repeatability (*3)	X, Y	±0.015 (mm)
	Z	±0.01 (mm)
	C	±0.02(deg)
Cycle time (*4) (When payload mass is 2 kg)		0.29(sec)
Drive system		By means of AC servo motors
Position detection method		Absolute
Cleanness level (*5)		Ten (10) or less dust particles of 0.1 μm or over in diameter, which exist in 1 cft (28,317 cm ³) of a sample area. Equivalent to clean class 3 defined by ISO
Air suction volume		60 normal liters/min

- *1: The structure of the robot controller is not of a clean type.
- *2: When the mass of load exceeds 1 kg, or when the gravity center position of load is away from the axis 4 center position, both the speed and acceleration should be reduced, using the PAYLOAD command.
- *3: The ambient temperature is predetermined at 20°C.
- *4: Shuttle time for rough positioning in horizontal direction of 300 mm and vertical direction of 25 mm.
- *5: When the air suction volume is 60 normal liters/min, down flowrate in the clean room is 0.4 m/s or over.

2. Transportation

2.1 Unpacking and Transport

The robot and controller are shipped either in wooden crates or cardboard boxes. Open the packages in a location easily accessible, where the equipment is to be installed. Take careful precautions not to damage the robot and controller.

After opening the packages, make sure that all the accessories are present and that no part has been damaged during transport.

The package posture and contents of the wooden crates and cardboard boxes are the same as in the standard robot. For details, see the TH450A/TH550A/TS3000 Installation and Transportation Manual or the THP550/TS3000 Installation and Transportation Manual provided separately.

2.2 Mass and Outer Dimensions

The mass and outer dimensions of the robot at the time of transport are shown in Figs. 2.1 to 2.3.

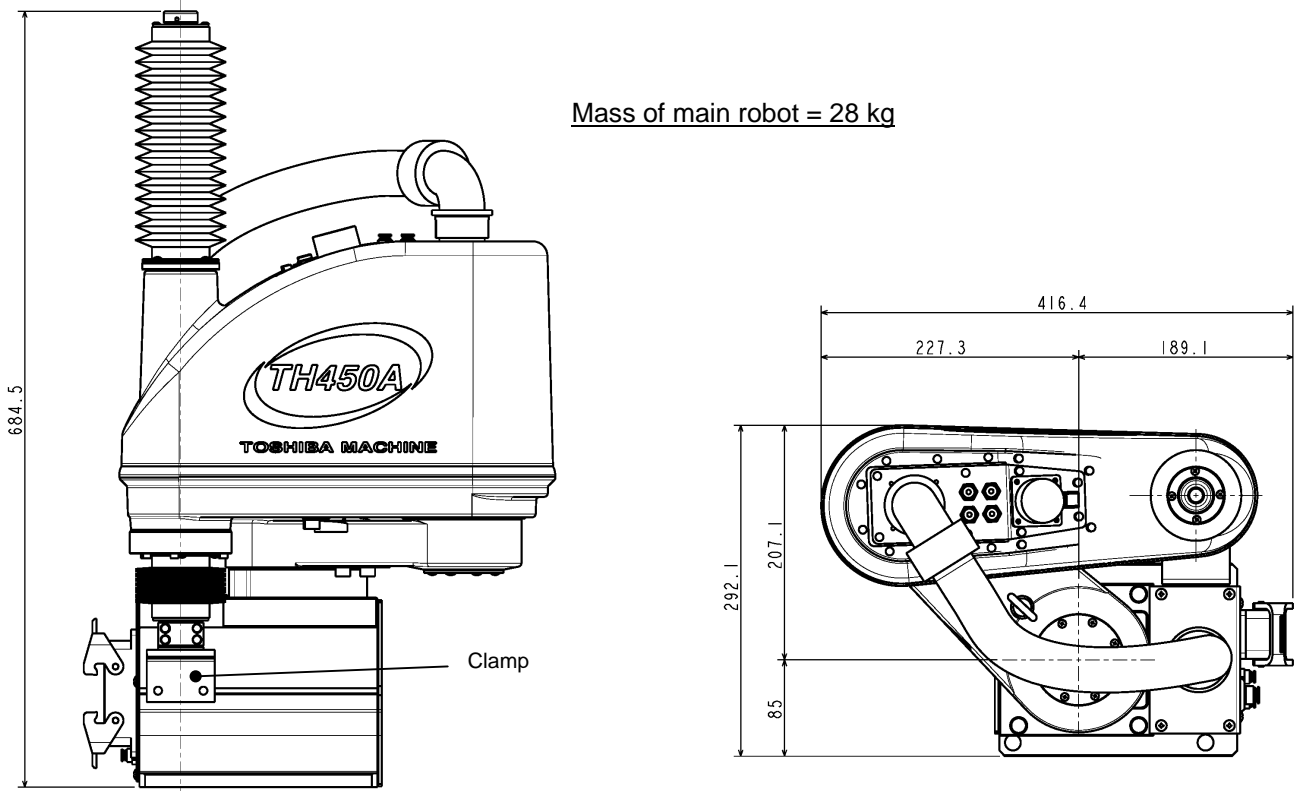

Fig. 2.1 Outer dimensions at transport (TH450A-CRB)

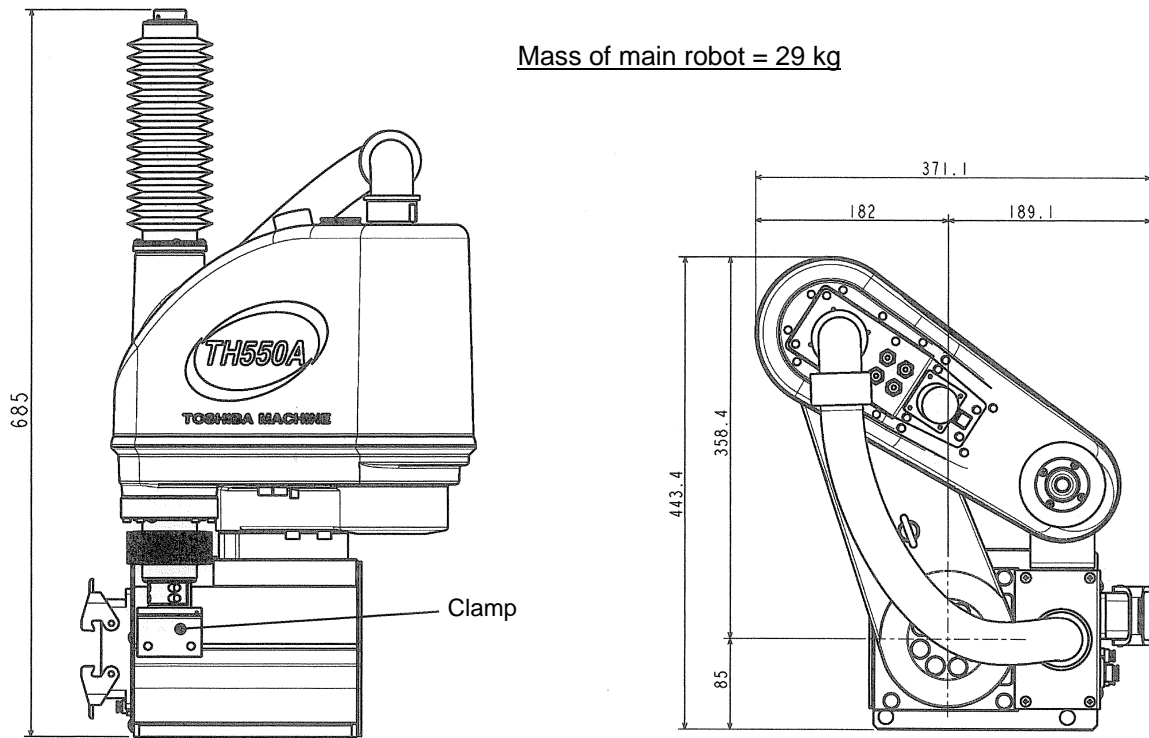

Fig. 2.2 Outer dimensions at transport (TH550A-CRB)

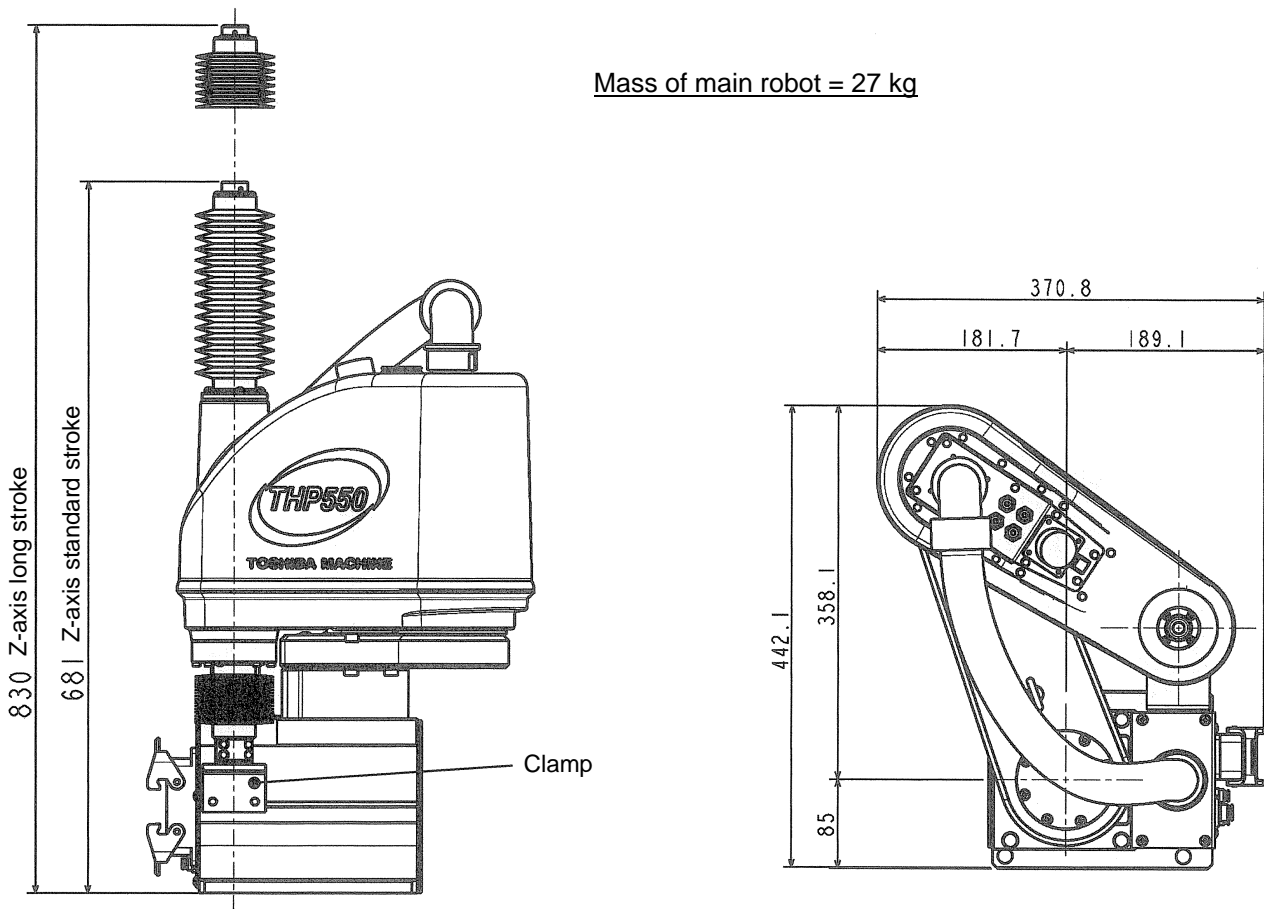

Fig. 2.3 Outer dimensions at transport (THP550-CRB)

2.3 Cautions on Transporting the Robot

The clean type robot equals the standard robot added with two (2) bellows. The precautions to be taken at transport are stated below. The precautions other than the below are the same as in the standard robot. For details, see the TH450A/TH550A/TS3000 Installation and Transportation Manual or the THP550/TS3000 Installation and Transportation Manual provided separately.

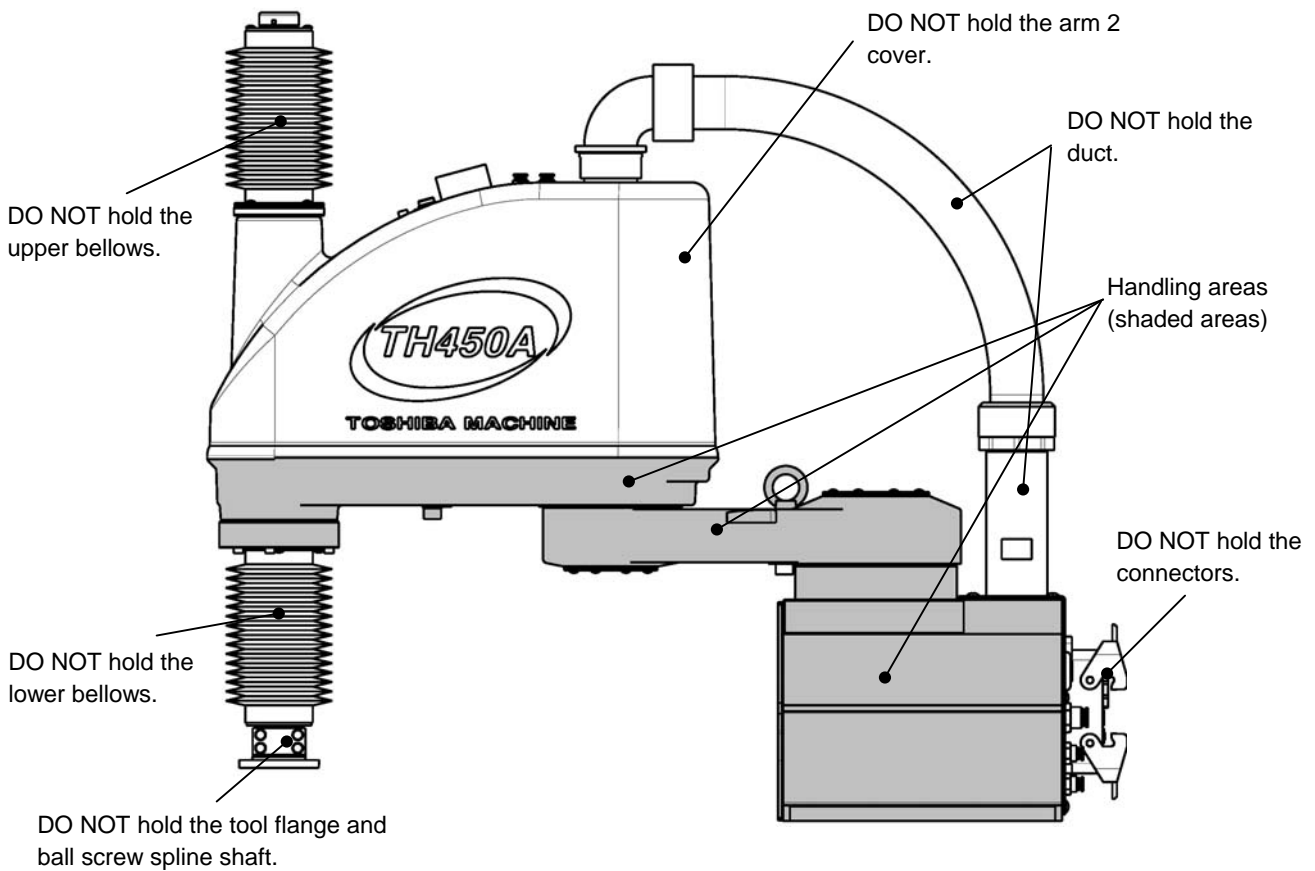

Fig. 2.4 Robot handling prohibited areas

After the installation, remove the clamp and eyebolt used for transport.



CAUTION

- When lifting up the robot by workers, hold the shaded locations by hands, as shown in Fig. 2.4. If the ball screw spline shaft is held by hands, an unusually large force is exerted, resulting in a malfunction.
- If the bellows is held or gripped by hands, it may be broken due to friction with the parts inside.
- When carrying the robot by workers, take careful precautions to prevent their hand or leg from being caught in the robot.
- The work should always be performed by two (2) or more workers.

3. Installation

3.1 Installation Environment

Table 3.1 shows the environmental conditions for the location in which the robot and controller are to be installed.

Table 3.1 Environmental conditions for robot and controller

Item	Specifications
Temperature	In operation : 0 to 40°C In storage : -10 to 50°C
Humidity	20 to 90% (Non-condensing) DO NOT install the robot and controller in a place where they are exposed to water or other liquid.
Altitude	1000 m or less
Vibration	In operation : 0.98 m/s ² or less
Dust	No inductive dust should exist. When using the robot and controller in a dusty environment, consult with us beforehand.
Gas	No corrosive or combustible gas should exist.
Sunlight	The robot and controller should not be exposed to direct sunlight.
Power noise	A heavy noise source should not exist nearby.
Magnetic field	A heavy magnetic field source should not exist nearby.



DANGER

- Do not place the robot or controller near combustible. Doing so could lead to fires if it ignites due to a fault, etc.

3.2 Air Suction Volume

It is possible to maintain the equivalent to clean class 3 defined by ISO by sucking a specified volume of air from the quick-operated joint for air suction attached to the base cover (i.e., connector unit of the base).

The air suction unit and suction air tube (8mm-dia.) should be provided by the customer.

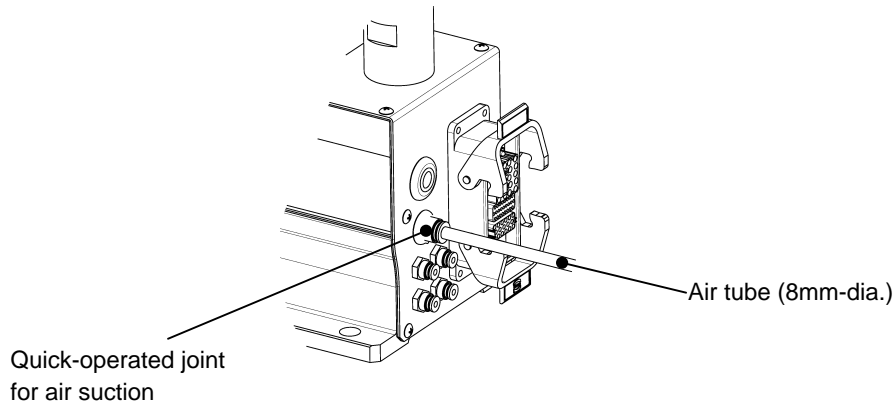

Air suction volume	60 normal liters/min
Equivalent to clean class 3 defined by ISO	<ul style="list-style-type: none"> • The number of particles of 0.1 μm or larger shall be 1000 or less in a cubic meter of air. • The number of particles of 0.1 μm or larger shall be 29 or less in a cubic foot of air.



CAUTION

- In the clean room, the down flowrate should be 0.4 m/s or over.
- Unless air suction is executed, dust will generate.

3.3 Coordinate System

The robot's joint angle origin (0° or 0 mm position) is factory-calibrated according to the base reference planes. Figs. 3.1 to 3.2 show the base coordinate system (X_B , Y_B , Z_B) and origin of each axis joint angle.

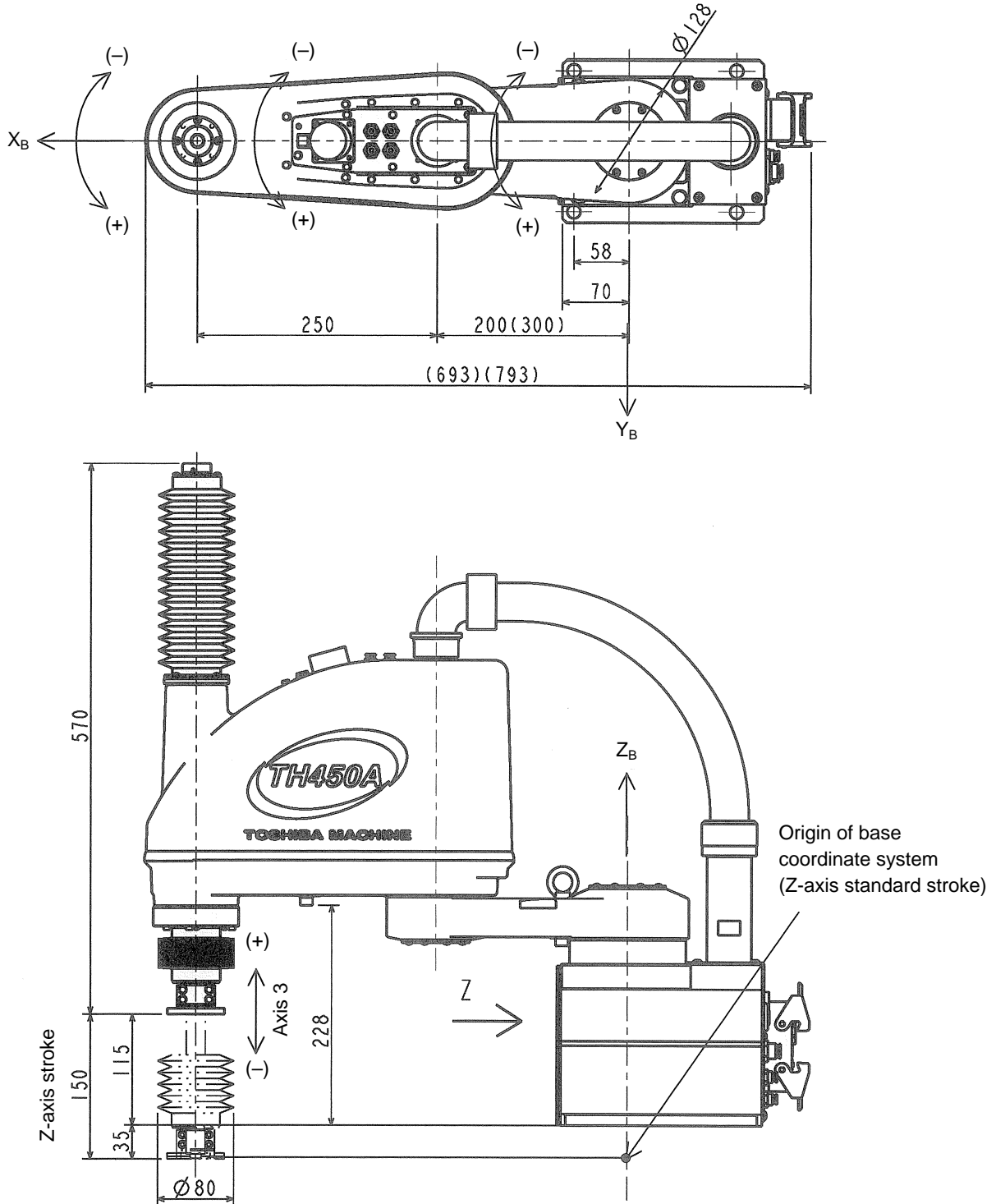

Fig. 3.1 Base coordinate system and joint angle origin (TH450A-CRB/TH550A-CRB)

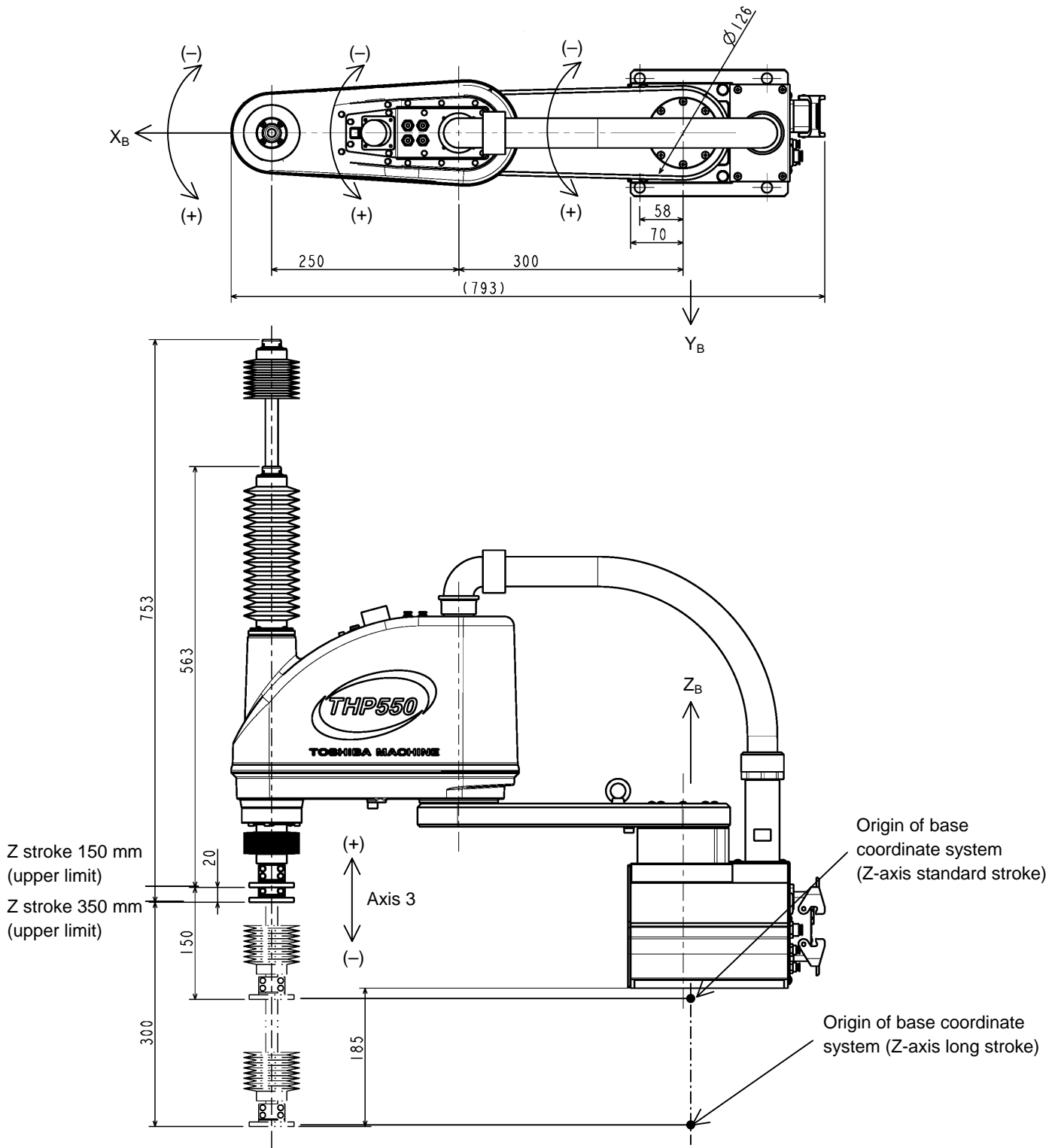

Fig. 3.2 Base coordinate system and joint angle origin (THP550-CRB)

3.4 Installing the Robot

The robot is secured, using the set holes on the base (four (4) places).

Use M12 hexagon socket head cap screws (made of stainless steel).

The robot installation method is shown in Fig. 3.3. The reference surfaces are provided on the base.

When you wish to adjust the robot position in the base coordinate system, or replace the robot with another one, provide appropriate reference surfaces and secure the robot by applying them to the reference surfaces of the base.



CAUTION

- The robot will suddenly accelerate and decelerate during operation. When installing it on a frame, make sure that the frame has sufficient strength and rigidity.

If the robot is installed on a frame that does not have sufficient rigidity, vibration will occur while the robot is operating, and could lead to faults.

When the robot is installed on the floor, secure it completely with anchor bolts, etc.

- Install the robot on a level place. Failure to do so could lead to a drop in performance or faults.

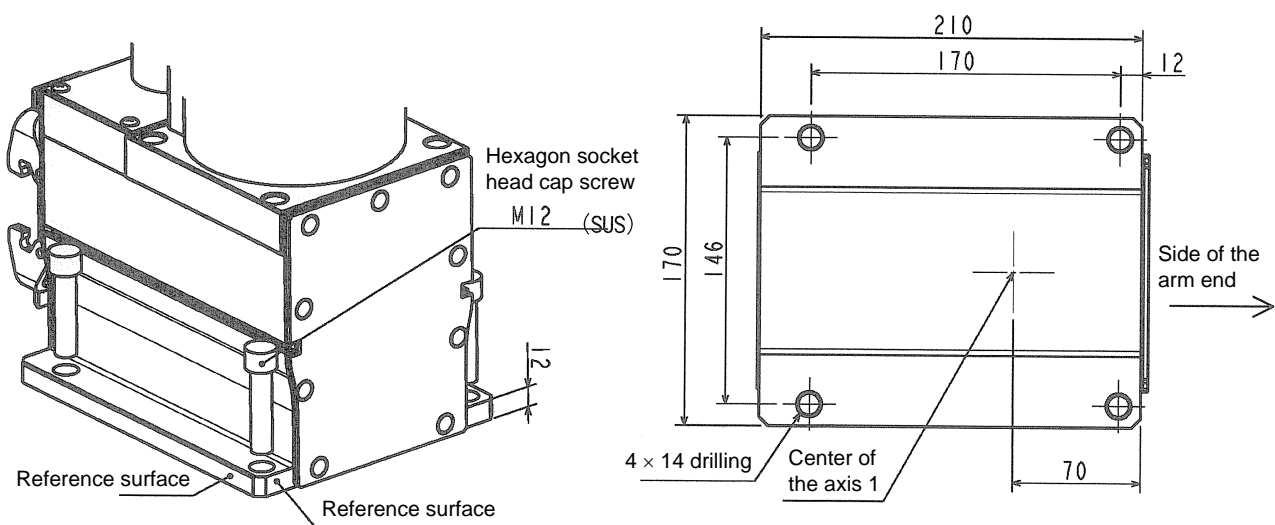

Fig. 3.3 Installation method

4. Tool Interface

Mounting of a tool and tool signals are the same as in the standard robot.

For details, see the TH450A/TH550A/TS3000 Installation and Transportation Manual or the THP550/TS3000 Installation and Transportation Manual provided separately.

4.1 Tool Air Piping

The robot is provided with four (4) air lines for the tool.

The outer diameter of the air pipelines is 4 mm. Fig. 4.1 shows the tool air piping.

The air control unit (oiler, regulator with gage and filter) and solenoid valves should be provided by the user.

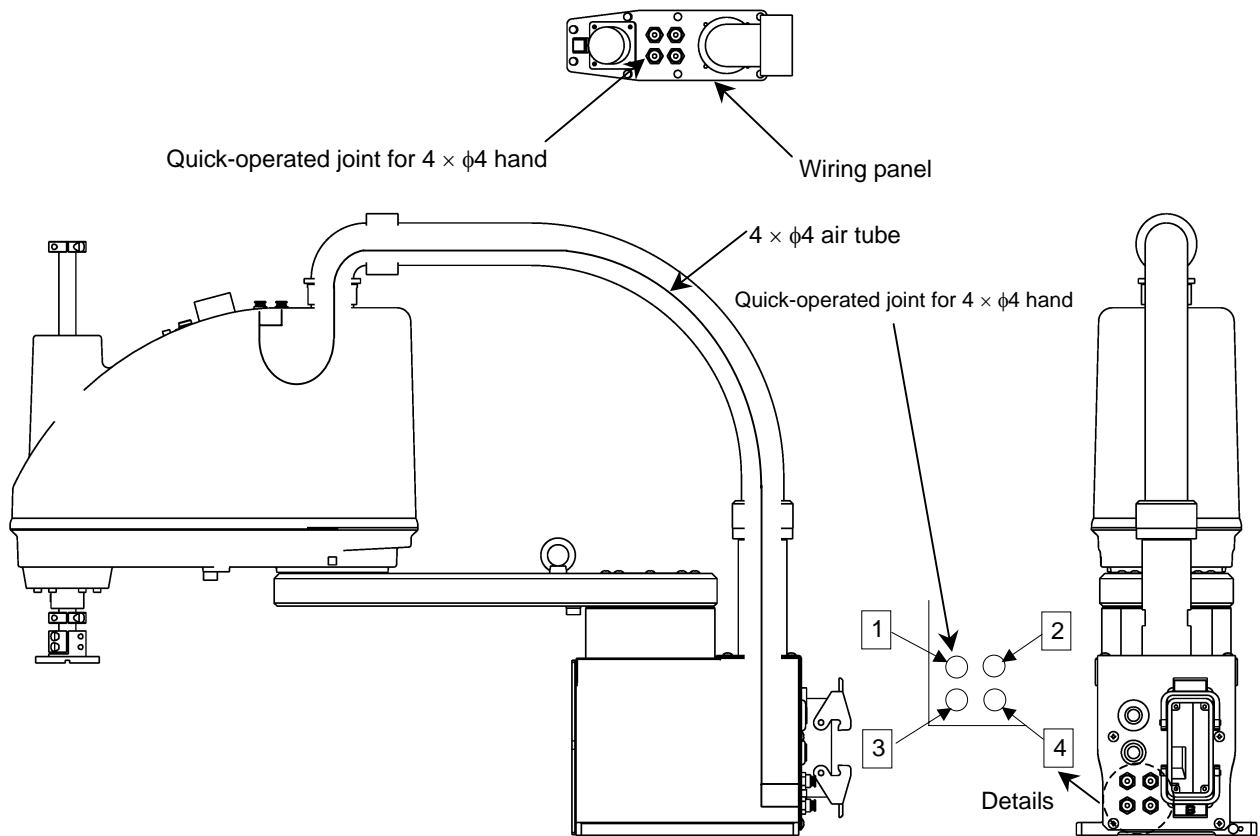

The air tube is identified by the number and color. At piping, make sure that each tube is connected properly, referring to the below-mentioned.

1 : Red 2 : White 3 : Blue 4 : Yellow

Air joint pitches of the panel

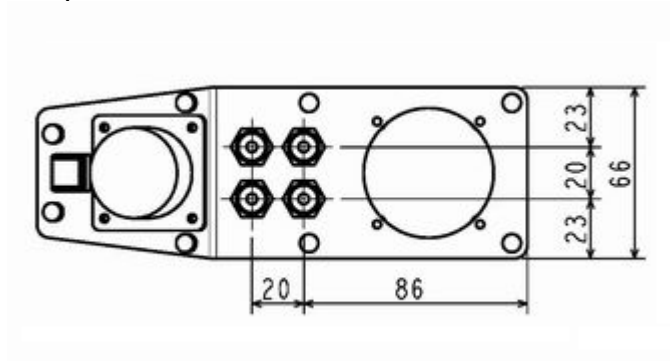

Fig. 4.1 Tool air piping

5. Maintenance

5.1 Items for Maintenance and Inspection

The maintenance schedule and maintenance procedures for the clean type robot are shown in Table 5.1 below.

The basic structure of the clean type robot is the same as that of the standard robot. For the maintenance schedule, maintenance procedures, contents of inspection, etc., see the THP550/TH450A/TH550A Maintenance of Instruction Manual provided separately.

Table 5.1 Maintenance items for clean type robot

D: Daily inspection Q: Quarterly inspection
S: Semi-annual inspection A: Annual inspection

Check position	Description	D	Q	S	A	Refer to
Check for bellows	Visually make sure that the upper and lower bellows are not damaged or cracked and in a good shape.	O	O	O	O	Para. 5.1.1
Replacement of bellows	Replace the bellows If it is damaged, or according to the maintenance schedule.				O	Para. 5.1.2
Filling grease to ball screw spline unit	Remove the bellows and fill the grease to the ball screw spline. After the filling, mount the bellows as it was set originally.			O	O	Para. 5.1.3



DANGER

- Be sure to turn off the main power switch of the controller before approaching the robot for maintenance and inspection.



CAUTION

- When replacing the bellows with a new one, dust will generate. Before the replacement, therefore, move the robot to a place where dust generation poses no problem at all.

5.1.1 Check for Bellows

Visually make sure that each bellows is not found broken, worn out, twisted or folded during robot operation or stop.

If it is found broken or worn out, the cleanness level will drop. Replace it with a new one immediately. If the bellows is twisted or folded, it will be damaged. When this happens, correctly set it again.

5.1.2 Replacement of Bellows

Replace the bellows if it is damaged, or according to the maintenance schedule.

For the maintenance schedule, replace the bellows when the axis 3 has shuttled 30 million counts or when one (1) year has passed after the robot operation, whichever comes first.

5.1.3 Filling Grease to Ball Screw Spline Unit

Dismantle each bellows, referring to Para. 5.4. Then fill the grease to the ball screw spline unit, referring to the THP550/TH450A/TH550A Maintenance of Instruction Manual provided separately.

5.2 Layout of Robot Components

The layout of the robot mechanical components is shown in Fig. 5.1 and Fig. 5.2.

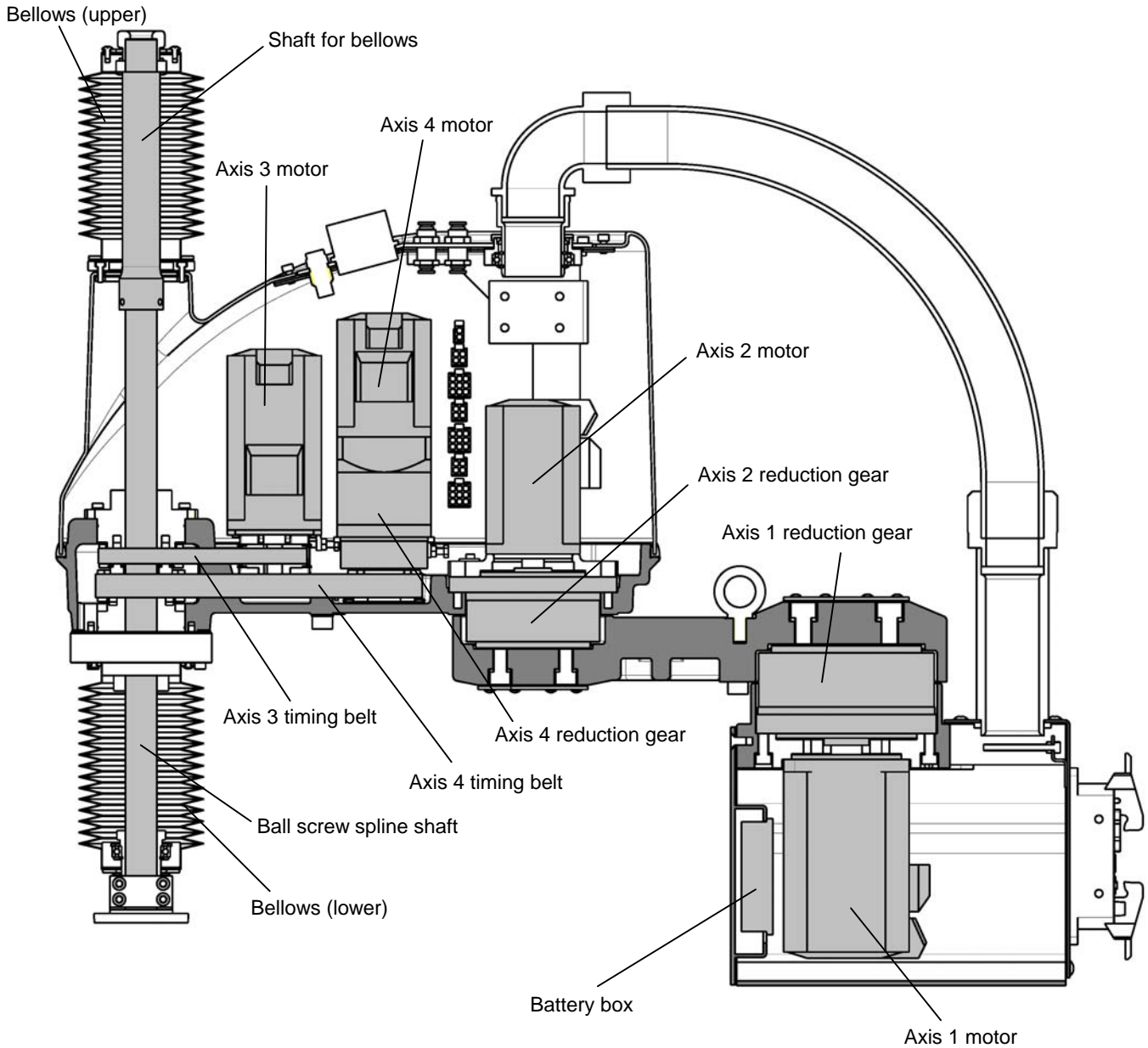

Fig. 5.1 Layout of robot mechanical components (TH450A-CRB/TH550A-CRB)



CAUTION

- When replacing the bellows with a new one or when mounting and dismounting the cover, dust will generate. Before starting the work, therefore, move the robot to a place where dust generation poses no problem at all.

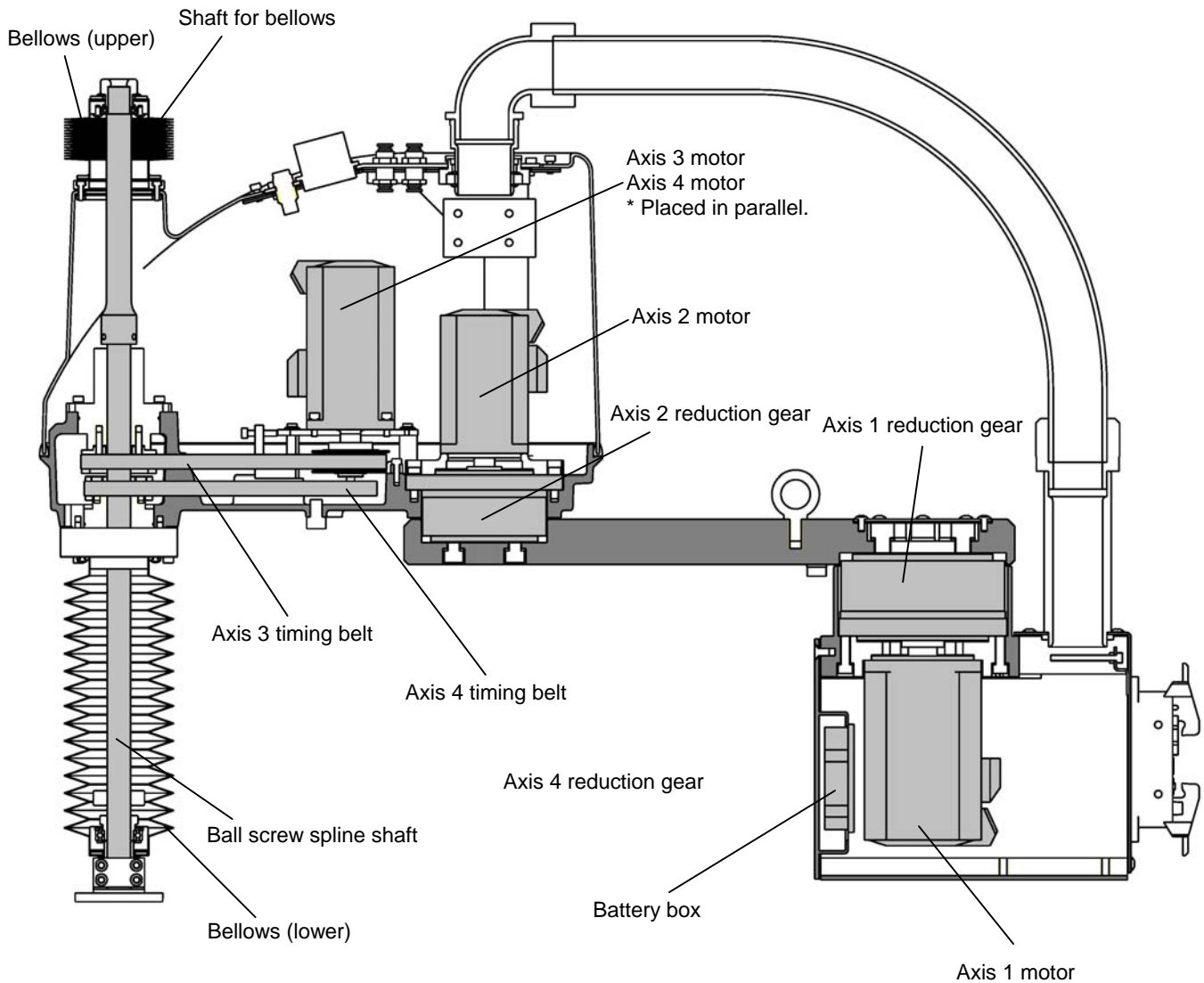

Fig. 5.2 Layout of robot mechanical components (THP550-CRB)



CAUTION

- When replacing the bellows with a new one or when mounting and dismounting the cover, dust will generate. Before starting the work, therefore, move the robot to a place where dust generation poses no problem at all.

5.3 Mounting and Dismounting Covers

Packing is attached to each cover set surface of the clean type robot. Strictly observe the following procedures to mount and dismount each cover.



DANGER

- Before mounting and dismounting each cover, be sure to turn off the main power (“POWER”) switch.
- When opening each cover, make sure that water or contaminant will not enter the robot. If the power is supplied while water or contaminant is left in the robot, you may get an electric shock or the robot may be damaged, which is very dangerous.

5.3.1 Base Cover

In all, two (2) base covers are provided; the cover concurrently used for connector panel and the cover concurrently used for battery box.

The replacement procedures for the former cover (i.e., cover concurrently used for connector panel) are the same as those for the standard robot.

The cover concurrently used for the battery box is secured to the base with nine (9) hexagon flat head screws (M5 × 10) by inserting the packing. As the cover is connected with the connectors inside, DO NOT pull out the cover by force.

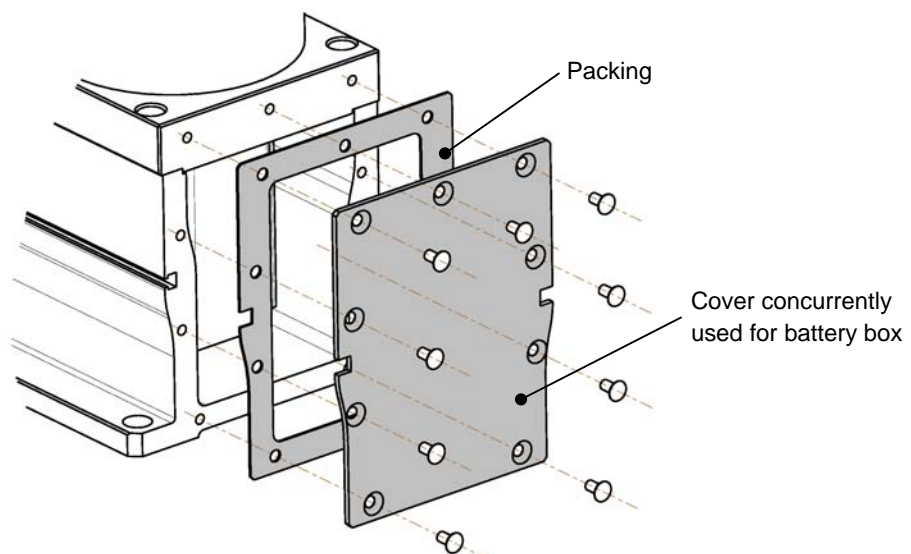

Fig. 5.3 Cover concurrently used for battery box



CAUTION

- Be sure to attach the packing when mounting the cover. Otherwise, the cleanness level will deteriorate.

5.3.2 Arm 1 Covers

The arm 1 covers are provided above the axis 1 (arm cover 1). Each cover is secured to the arm 1 with eight (8) cross-recessed truss head screws (M4 × 6) by inserting the packing.

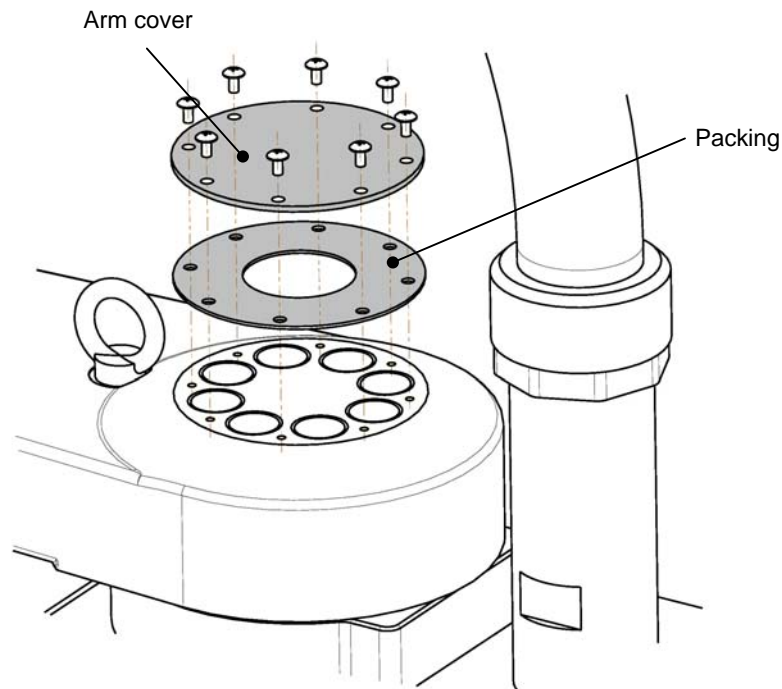

Fig. 5.4 Arm 1 cover TH450A-CRB/TH550A-CRB

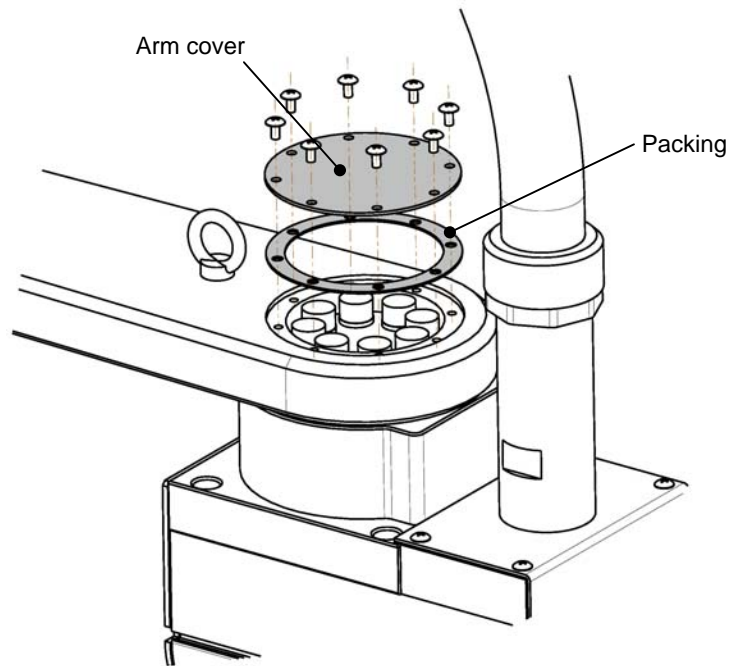

Fig. 5.5 Arm 1 cover THP550-CRB



CAUTION

- Be sure to attach the packing when mounting the cover. Otherwise, the cleanliness level will deteriorate.

5.3.3 Arm 2 Cover

The arm 2 cover is secured to the cover securing bracket with twelve (12) hexagon socket head bolts (M4 × 8). Due to the clean type robot, the bellows (upper) is attached to the cover.

To dismount the arm 2 cover, the bellows should be disconnected first. For the replacement procedures for the bellows, see Para. 5.4.

In the descriptions below, the upper bellows is already removed from the cover.

As the cover is embedded to the arm 2, remove the bolts and the cover can be lifted up. It may be hard to disconnect the embedded section. The packing attached to the cover edge can be disconnected together with the cover. When disconnecting the arm 2 cover completely, move the axis 3 to the lower limit beforehand.

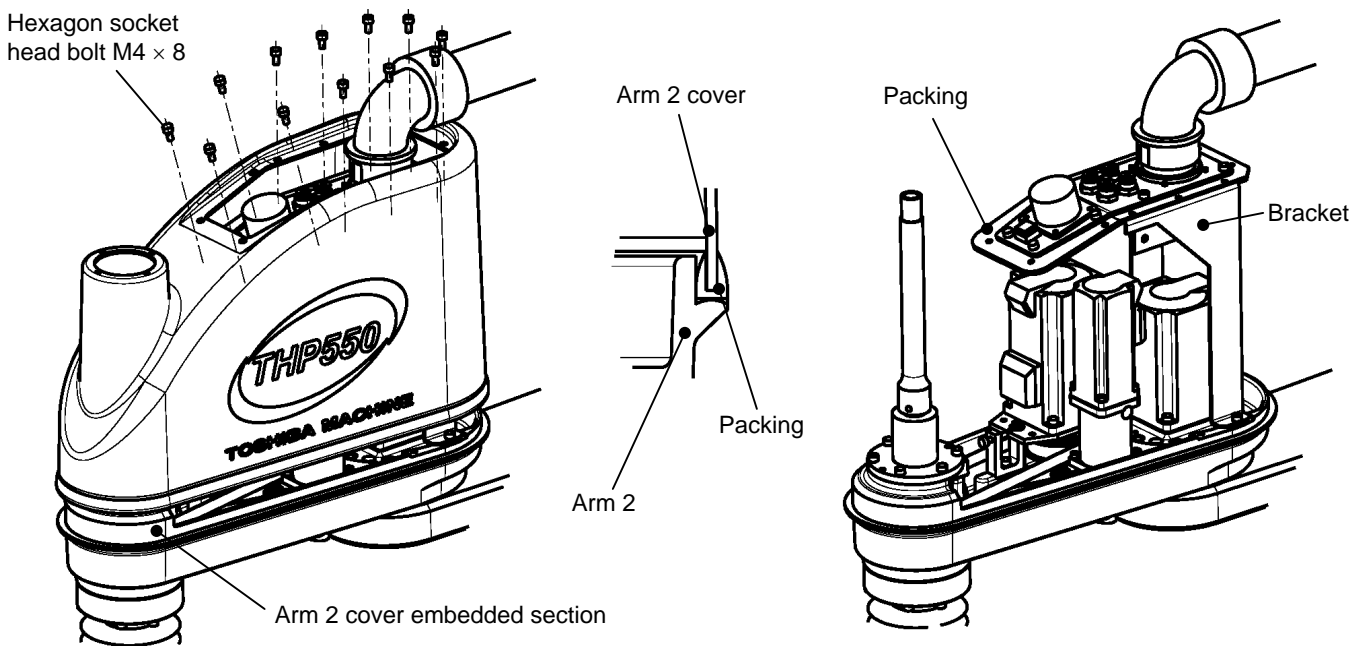

Fig. 5.6 Arm 2 cover (same for all the models, except the logo)

Apply the locktite to all the mounting bolts, when mounting the cover.

5.4 Replacing Bellows



DANGER

- Before replacing the bellows with a new one, be sure to turn off the controller power and remove the power plug.

5.4.1 Replacement Procedures for Bellows (Lower)

- 1) Remove the tool flange, followed by the keep plate under the bellows.
- 2) Remove the keep plate above the bellows, then pull the bellows downward.

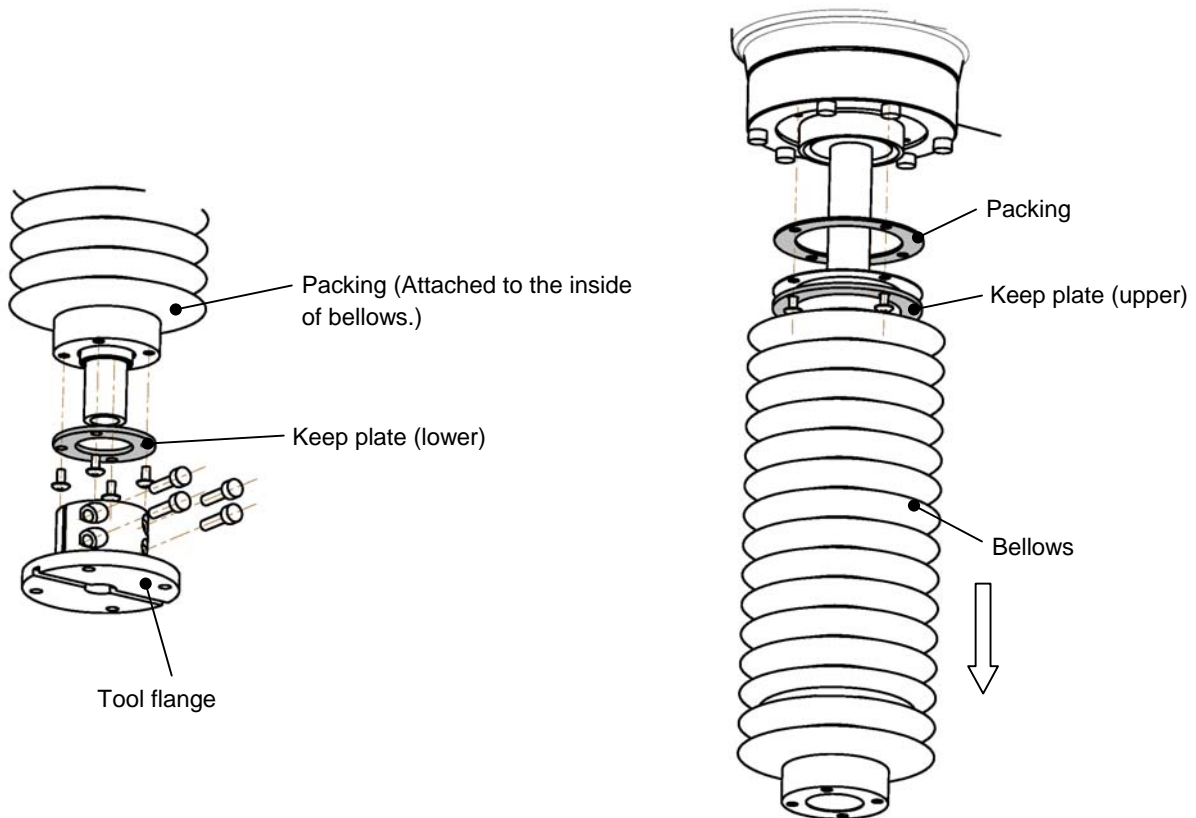

Fig. 5.7 Bellows (lower)

- 3) To mount the bellows, observe the above steps in the reversed order. Be sure to attach the packing.



CAUTION

- When dismantling the bellows, DO NOT pull it out by force. Otherwise, the bellows may rupture.
- Be sure to attach the packing. Otherwise, the cleanliness level will deteriorate.

5.4.2 Replacement Procedures for Bellows (Upper)

- 1) Remove the three (3) set screws (3×6 SUS), then pull out the wiring guide upward.
- 2) Remove the cross-recessed truss head screws (3×6 SUS) securing the bellows. (Four (4) screws each on the top and bottom sides; a total of eight (8) screws) The bellows is secured by the keep plate with the packing inserted on both the top and bottom sides.
- 3) Pull out the bellows upward. It can be pulled out even when the bearing case remains attached.
- 4) To remove the arm 2 cover, pull out the bearing case upward. The bearing is secured with four (4) cross-recessed truss head screws in the bearing case. The bearing need not be disconnected.

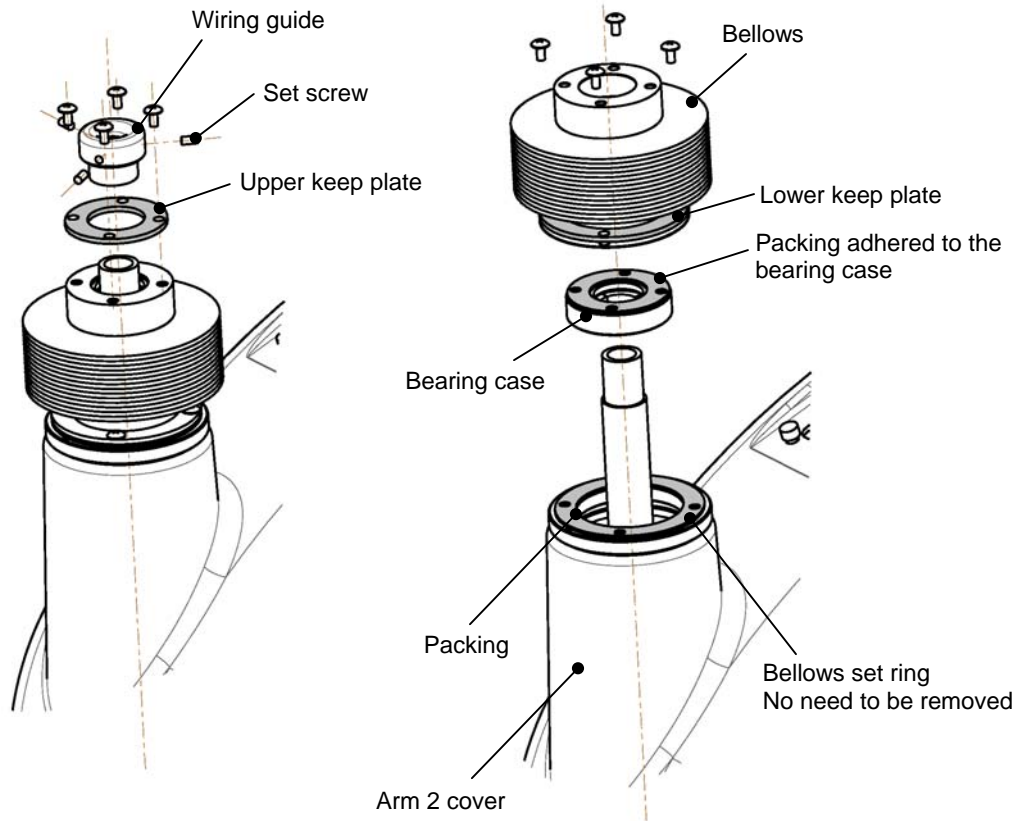

Fig. 5.7 Bellows (upper)

- 5) To mount the bellows, observe the above steps in the reversed order. Be sure to attach the packing.



CAUTION

- When dismantling the bellows, DO NOT pull it out by force. Otherwise, the bellows may rupture.
- Be sure to attach the packing. Otherwise, the cleanliness level will deteriorate.

6. Replacement Parts for Maintenance

6.1 Replacement Parts List for Maintenance

	Part name	Our dwg. No.	Unit code	Stroke	Q'ty	Remarks
1	Bellows	S854575	Y610A3GH0	Z150	2	TH450A-CRB/TH550A-CRB
2	Bellows	S849728	Y610A3F90	Z150	2	THP550-CRB
3	Bellows	S854887	Y610A3FT0	Z300	2	THP550-Z-CRB
4	Ball-screw	H846618	Y610A3GF0	Z150	1	TH450A-CRB/TH550A-CRB
5	Ball-screw	H846629	Y610A3HP0	Z150	1	THP550-CRB
6	Ball-screw	H846630	Y610A3HY0	Z300	1	THP550-Z-CRB

The replacement parts for maintenance other than the above are the same as those of the TH450A/TH550A/THP550 robot. For details, see the THP550/TH450A/TH550A Maintenance of Instruction Manual provided separately.

- When you wish to purchase the replacement parts for maintenance, make sure of the serial number of the main robot and contact us.

APPROVED BY:

F. Uehara.

CHECKED BY:

K. Kido

PREPARED BY:

Y. Nakai