

TH650A/TS3100

Industrial Robot 

INSTRUCTION MANUAL

INDUSTRIAL ROBOT

TRANSPORTATION AND INSTALLATION MANUAL

Notice

1. Make sure that this instruction manual is delivered to the final user of Toshiba Machine's industrial robot.
2. Before operating the industrial robot, read through and completely understand this manual.
3. After reading through this manual, keep it nearby for future reference.

October, 2010

TOSHIBA MACHINE CO., LTD.

NUMAZU, JAPAN

Copyright 2007 by Toshiba Machine Co., Ltd.
All rights reserved.

No part of this document may be reproduced in any form without obtaining prior written permission from Toshiba Machine Co., Ltd.

The information contained in this manual is subject to change without prior notice to effect improvements.

Preface

This manual describes the basic specifications of the industrial robot and controller, and how to unpack and install them. Specifically, it describes how to unpack the shipment containing the equipment, how to install the equipment, how to connect wiring and air piping, and how to attach tools. Be sure to look through this manual before unpacking the shipment.

Before beginning the work according to this manual, read through the Safety Manual so that you can understand the safety measures.

This manual is divided into the following five (5) sections:

Section 1 Specifications

This section describes the basic specifications and names of respective units of the robot and controller.

Section 2 Transportation

This section describes how to remove the robot and controller from their boxes and how to transport them to the installation site. This section also discusses how to temporarily store the equipment after unpacking the shipment.

Section 3 Installation

This section discusses the equipment installation environment, space requirements, and how to install the equipment.

Section 4 System Connections

This section describes how to connect the robot, controller and peripheral equipment.

Section 5 Tool Interface



This section describes how to connect the tool to the robot arm and how to connect pipes and wires to the tool. This section also discusses maximum permissible loads of the tool.

Precautions on Safety

Important information on the robot and controller is noted in the instruction manual to prevent injury to the user and persons nearby, prevent damage to assets and to ensure correct use.

Make sure that the following details (indications and symbols) are well understood before reading this manual. Always observe the information that is noted.



[Explanation of indications]

Indication	Meaning of indication
 DANGER	This means that "incorrect handling will lead to fatalities or major injuries".
 WARNING	This means that "incorrect handling will lead to fatalities or serious injuries."
 CAUTION	This means that "incorrect handling may lead to personal injuries *1) or physical damage *2)".

*1) Injuries refer to injuries, burns and electric shocks, etc., which do not require hospitalization or long term treatment.

*2) Physical damage refers to major fires due to destruction of assets or resources.

[Explanation of symbols]





Symbol	Meaning of symbol
	This means that the action is prohibited (must not be done). The details of the actions actually prohibited are indicated with pictures or words in or near the symbol.
	This means that the action is mandatory (must be done). The details of the actions that must be done are indicated with pictures or words in or near the symbol.
	This means danger and caution. The details of the actual caution are indicated with pictures or words in or near the symbol.

CAUTION

- Always read through the Safety Manual provided separately before starting actual work to ensure safety work covering from the robot installation to operation.

[Installation and transportation]

Always observe the following items to safely use the robot.

 DANGER	
 Prohibited	<ul style="list-style-type: none"> • DO NOT install or operate if any parts are damaged or missing. Doing so could lead to electric shocks, fires or faults. • DO NOT install the robot where it may be subject to fluids such as water. Doing so could lead to electric shocks, fires or faults. • Do not place the robot near combustible matters. Doing so could lead to fires if the matter ignites due to a fault, etc.
 Mandatory	<ul style="list-style-type: none"> • Always secure the robot with the attached clamps before transporting it. Failure to do so could lead to injuries if the arm moves when the robot is suspended. • Wire the robot after installation. Wiring the robot before installation could lead to electric shocks or injuries. • Always use the power voltage and power capacity designated by Toshiba Machine. Failure to do so could lead to device faults or fires. • Always use the designated power cable. Using a cable other than that designated could lead to fires or faults.
 Always ground	<ul style="list-style-type: none"> • Completely connect the grounding cable. Failure to do so could lead to electric shocks or fires if a fault or fault current occurs. Noise could lead to malfunction. Also, it could cause mis-operation by noise.



 CAUTION	
 Prohibited	<ul style="list-style-type: none">• NEVER lift the robot by the arm 2 cover or arm 2. Doing so will apply an excessive force on the robot's mechanism section and could lead to faults.• For the controller, secure the ample space for air vent. Heating of controller could lead to malfunction.
 Mandatory	<ul style="list-style-type: none">• When lifting the robot, lift it up slowly. The robot will tilt slightly, so lifting it up suddenly could be hazardous.• When storing the robot, secure it to the base. The robot will be unstable if just set down, and it could tilt over.

Table of Contents

	Page
1. Specifications	10
1.1 Name of Each Part	10
1.2 External Dimensions	11
1.3 Specifications Table	12
2. Transportation	14
2.1 Unpacking	14
2.2 Transportation	16
2.2.1 Mass and Dimensions	16
2.2.2 Transporting the Robot	17
2.2.3 Transporting the Controller	19
2.3 Storage	20
2.3.1 Storage Precautions for the Robot	20
2.3.2 Storage Precautions for the Controller	20
3. Installation	21
3.1 Installation Environment	21
3.2 Robot Installation	22
3.2 Robot Installation	22
3.2.1 External Dimensions	22
3.2.2 Working Envelope	24
3.2.3 Coordinate System	25
3.2.4 Installing the Robot	26
3.3 Installing the Controller	27
3.3.1 External Dimensions	27
3.3.2 Precautions for Direct Installation	27
3.3.2 Precautions for Direct Installation	28
3.3.3 Rack Mounting Dimensions	29
3.3.4 Precautions for Rack Mounting	29
3.4 Precautions for Handling the Teach Pendant	31
3.5 Safety Measures	32
4. System Connections	33
4.1 Cable Wiring	33
4.1.1 Connector Arrangement on the Controller	33

4.1.3	Connecting the Motor Cable “MOTOR” (② of Fig. 4.1) (Cable attached)	36
4.1.5	Connecting the Robot Control Signal Cable “HAND” (④ of Fig. 4.1) (Cable: option)	37
4.1.6	Connecting and Disconnecting Cables	37
4.1.7	Examples of Connector Terminal Arrangement	39
4.2	Controller Connector Signals	42
4.2.1	Connector Signal Connection Diagrams	42
4.2.2	Jumpers for Safety Related Signals	42
4.3	Separating Control Panel from Controller	44
4.3.1	Removing Control Panel	44
4.3.2	Cable between Controller and Control Panel	44
4.3.3	Control Panel Mounting Dimensions	45
4.3.4	Mounting Dummy Panel on Controller	46
4.3.5	Dimensions when Separating Control Panel	47
5.	Tool Interface	48
5.1	Mounting Tool	48
5.2	Tool Wiring and Piping	49
5.2.1	Tool Signals (Controller Side)	49
5.2.2	Tool Wiring	53
5.2.3	Tool Air Piping	62
5.3	Permissible Load Conditions and Program Setting	64
5.3.1	Permissible Load Conditions	64
5.3.2	Load Conditions and Program Setting	65
5.3.3	Setting Maximum Speed and Robot Acceleration/Deceleration for Load Conditions	69

Tables and Drawings

	Page
Fig. 1.1 Name of each part.....	10
Fig. 1.2 External dimensions of the robot.....	11
Fig. 2.1 Packaging state.....	15
Fig. 2.2 Outer dimensions at transport.....	16
Fig. 2.3 Lifting up the robot	17
Fig. 2.4 Robot handling areas (shaded areas).....	18
Table 3.1 Environmental conditions for robot and controller	21
Fig. 3.1 External view	23
Fig. 3.2 Working envelope	24
Fig. 3.3 Base coordinate system and joint angle origin.....	25
Fig. 3.4 Setting method	26
Fig. 3.5 External view of controller	27
Fig. 3.6 Controller ventilation space	28
Fig. 3.7 Screw hole dimensions for securing controller.....	29
Fig. 3.8 Removing upper cover	30
Fig. 3.9 Clearance of controller front side	31
Fig. 4.1 Robot controller connector arrangement.....	33
Table 4.1 Power supply specifications	34
Fig. 4.2 Robot side connector arrangement.....	36
Fig. 4.3 Connecting and disconnecting a circular connector.....	37
Fig. 4.4 Connecting and disconnecting a square connector	38
Fig. 4.5 Removing control panel.....	44
Fig. 4.6 Control panel mounting dimensions	45
Fig. 4.7 Mounting dummy panel.....	46
Fig. 4.8 Cable connections of dummy panel and control panel.....	47
Fig. 5.1 Tool mounting dimensions	48
Fig. 5.2 Wiring to PLC, etc.	54
Fig. 5.3 Tool wiring.....	56
Fig. 5.5 Procedures for relocating wiring panel	59
Fig. 5.6 Wiring method.....	61
Fig. 5.7 Tool air piping.....	63
Table 5.1 Permissible load conditions.....	64
Fig. 5.8 Robot tool.....	65
Fig. 5.9 Setting of maximum speed and acceleration/deceleration in relation to load mass	69
Fig. 5.10 Setting of maximum speed and acceleration/deceleration in relation to gravity center offset (Axes 1 and 2)	70
Fig. 5.11 Setting of maximum speed and acceleration/deceleration in relation to gravity center offset (Axes 3 and 4)	71

1. Specifications

1.1 Name of Each Part

Fig. 1.1 shows the name of each part of the robot.

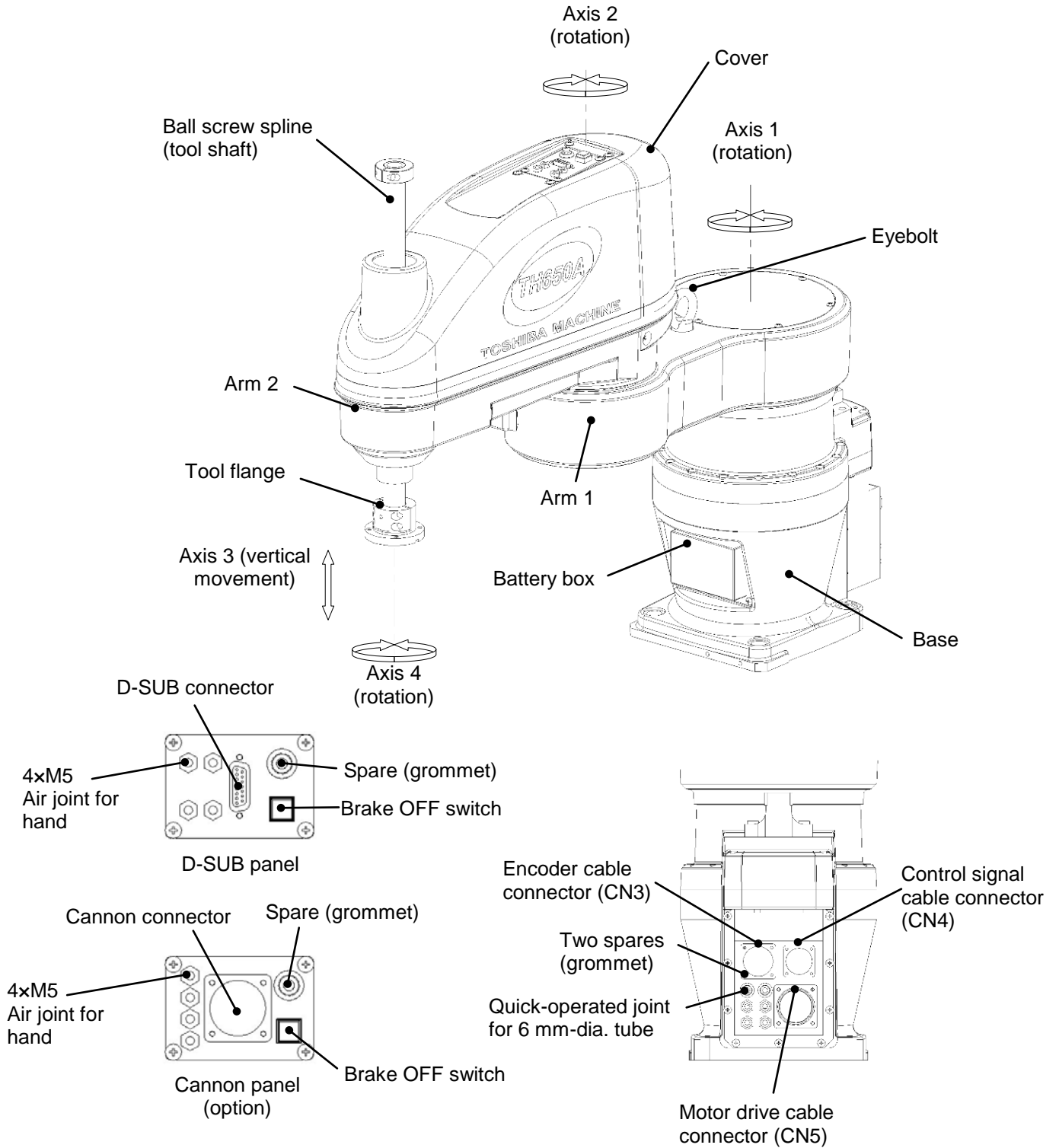

Fig. 1.1 Name of each part

1.2 External Dimensions

Fig. 1.2 refers to the external dimensions of the robot.

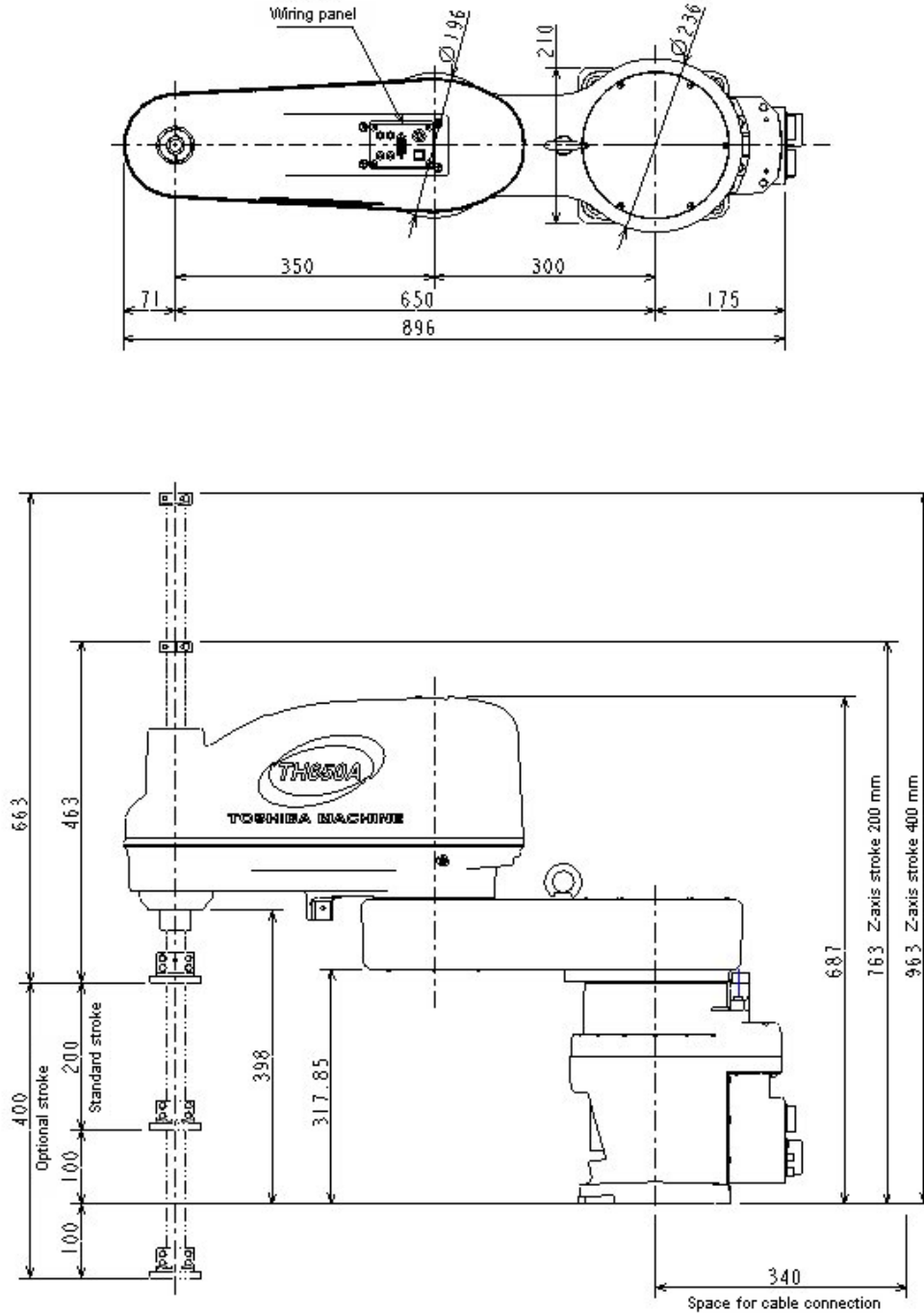

Fig. 1.2 External dimensions of the robot

1.3 Specifications Table

Item		Specifications
Structure		Horizontal multi-joint type SCARA robot
Model		TH650A
Applicable controller		TS2100
Mass of actuator		52 kg
No. of controlled axes		Four (4)
Arm length		650 mm (300 mm + 350 mm)
Motor capacity	Axis 1	1,000 (W)
	Axis 2	600 (W)
	Axis 3	400 (W)
	Axis 4	400 (W)
Operating range	Axis 1	±160 (deg)
	Axis 2	±143 (deg)
	Axis 3	200 (mm) [Option: 400 (mm)]
	Axis 4	±360 (deg)
Maximum speed (*1)	Axis 1	340 (deg/s)
	Axis 2	600 (deg/s)
	Axis 3	2,050 (mm/s)
	Axis 4	1,700 (deg/s)
	Composite speed of axes 1 and 2	7.52 (m/s)
Rated payload mass		2 (kg)
Maximum payload mass		10 (kg)
Permissible load inertia (*1)		0.1 (kg·m ²)
Repeatability	X, Y	±0.01 (mm)
	Z	±0.01 (mm)
	C	±0.004 (deg)
Cycle time (*2) (When payload mass is 2 kg)		0.31 (sec)
Drive system		By means of AC servo motors
Position detection method		Absolute

- *1: When the mass of load exceeds 2 kg, or when the gravity center position of load is away from the axis 4 center position, both the speed and acceleration should be reduced, using the PAYLOAD command.
- *2: Shuttle time for rough positioning in horizontal direction of 300 mm and vertical direction of 25 mm.



CAUTION

Put the Z-axis (axis 3) in the raised position as much as possible, when moving Axes 1, 2, and 4.

Moving Axis 1, 2, or 4 when the Z-axis is in low positions can lead to premature damage to the ball screw spline (Z-axis shaft).

If Axis 1, 2, or 4 must be moved while the Z-axis is in low positions due to unavoidable circumstances, prevent the ball screw spline vibrations by using the SPEED, ACCEL/DECEL, and PAYLOAD commands to adjust the operation speed and acceleration.

If Axis 1, 2, or 4 is moved while the Z-axis is in low positions, be extremely careful not to collide with any objects. Even if Axis 1, 2, or 4 is moved at low speed, a collision or other impact with an object can damage the ball screw spline (Z-axis shaft) before alarm occurs.

2. Transportation

2.1 Unpacking

The robot and controller are shipped separately in corrugated cardboards. Fig. 2.1 shows each packaging state.

Open the packages in a location easily accessible, where the equipment is to be installed. Take careful precautions not to damage the robot and controller.

After opening the packages, make sure that all the accessories are present and that nothing has been damaged during transport.

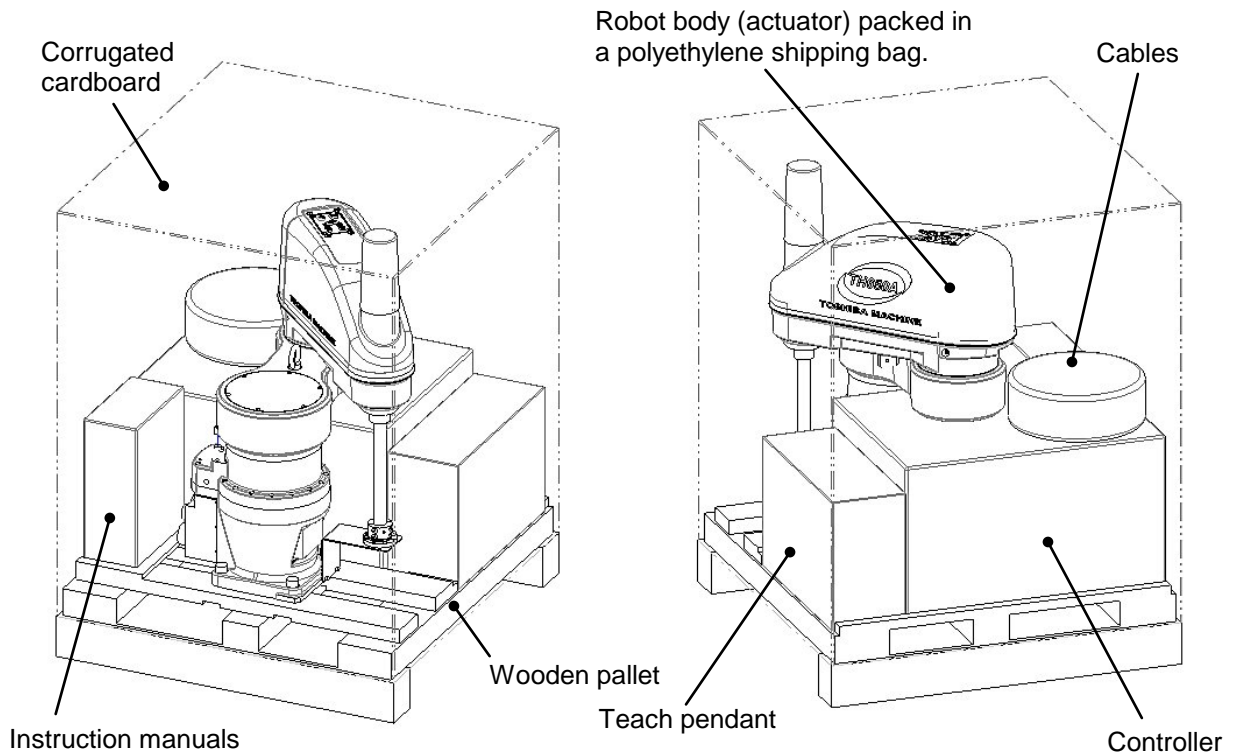

Accessories included in the instruction manuals

- System CD-RW: 1 pcs.
- CD-ROM for TCPRGOS (option): 1 pc.
- CD-ROM for TSPC (option): 1 pc.

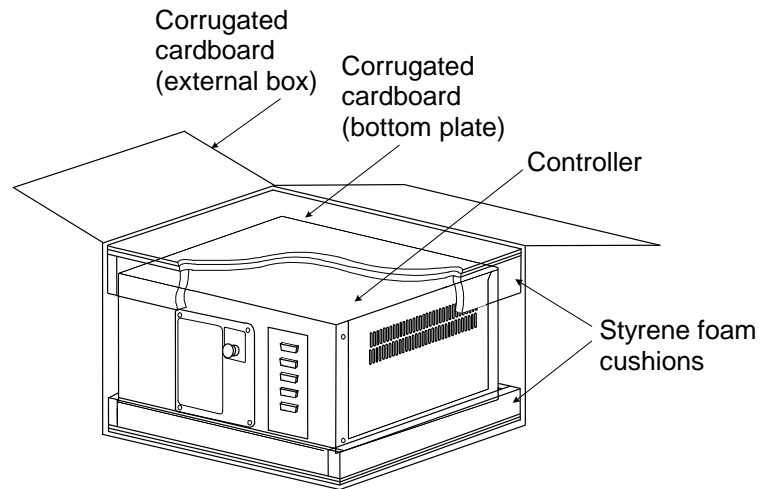

Accessories included in the controller package
EMS dummy connector: 1 pc.
SYSTEM dummy connector: 1 pc.
TP dummy connector: 1 pc.

Fig. 2.1 Packaging state



DANGER

- If any parts of the equipment are found damaged or any accessories are missing after the shipment containing the robot and controller have reached your office, **DO NOT** install and operate them. Otherwise, the equipment will malfunction. Contact Toshiba Machine immediately.
- Dispose of the wooden pallet, corrugated cardboards, polyethylene shipping bags and cushion material according to the customer's in-house regulations.

2.2 Transportation

Move the robot and controller very carefully. Make sure that no excessive impact or vibration is exerted on the equipment. If the equipment is to be subject to vibration over a long period, be sure to tighten all the clamp and base set bolts completely. If the equipment is to be moved to a location some distance from where it was unpacked, reposition the cushions as they were and put the equipment back into the corrugated cardboards.

2.2.1 Mass and Dimensions

The mass and outer dimensions of the robot are shown in Table 2.1.

For the mass and outer dimensions of the controller, see Fig. 3.5 of Para. 3.3.1.

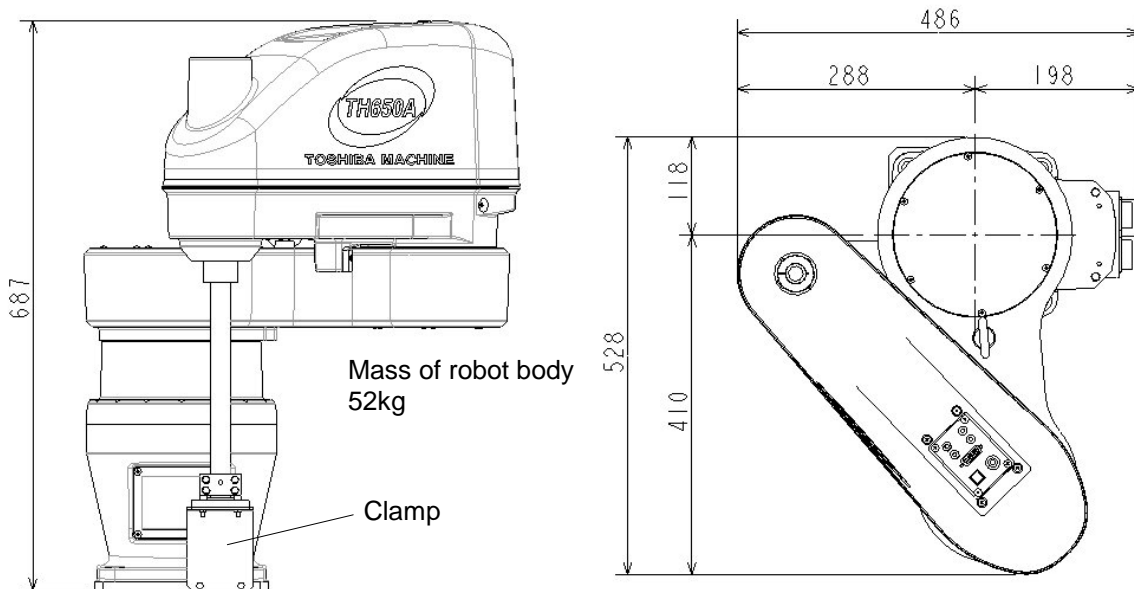

Fig. 2.2 Outer dimensions at transport

2.2.2 Transporting the Robot

In principle, the robot should be transported in the state shown in Fig. 2.2 above. Fold back and secure the arm with the attached clamp. (The robot is shipped in this posture. After you have unpacked the shipment, you should move it as it is.) At this time, take careful precautions not to impose a large force on the tool shaft.



DANGER

- Be sure to secure the arm with the attached clamp before transporting the robot. Failure to do so could cause a hazardous situation as the arm will move when the robot is lifted.

It is possible to lift up and transport the robot. Pass the wire through the attached eyebolt, then lift up the robot carefully, as shown in Fig. 2.3.

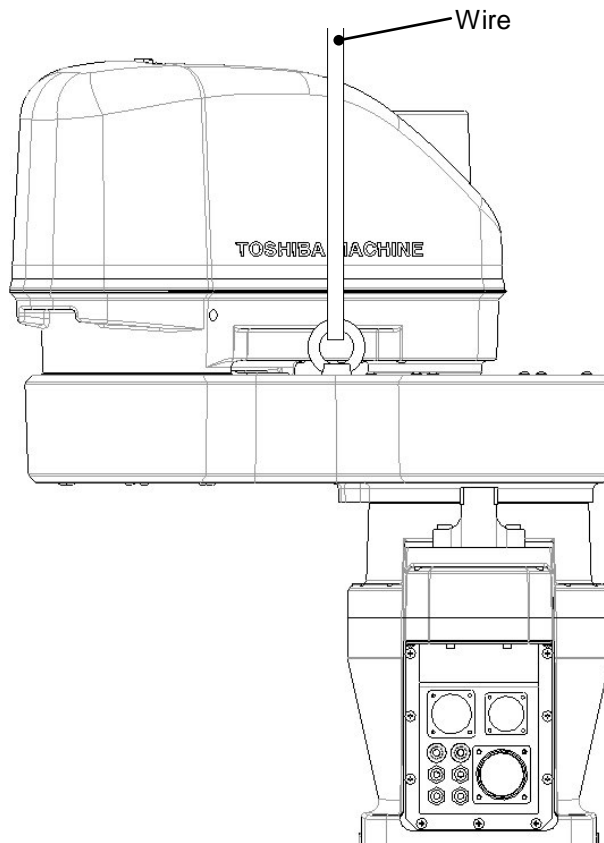

Fig. 2.3 Lifting up the robot



CAUTION

- The wire to be used should be such that can well withstand the mass of the robot.
- When lifting up the robot, it may tilt a little. Lift it up slowly.
- Lifting up and down should be performed carefully so that any impact cannot be exerted on the robot.
- When carrying the robot by workers, take careful precautions to prevent their hand or leg from being caught in the robot.

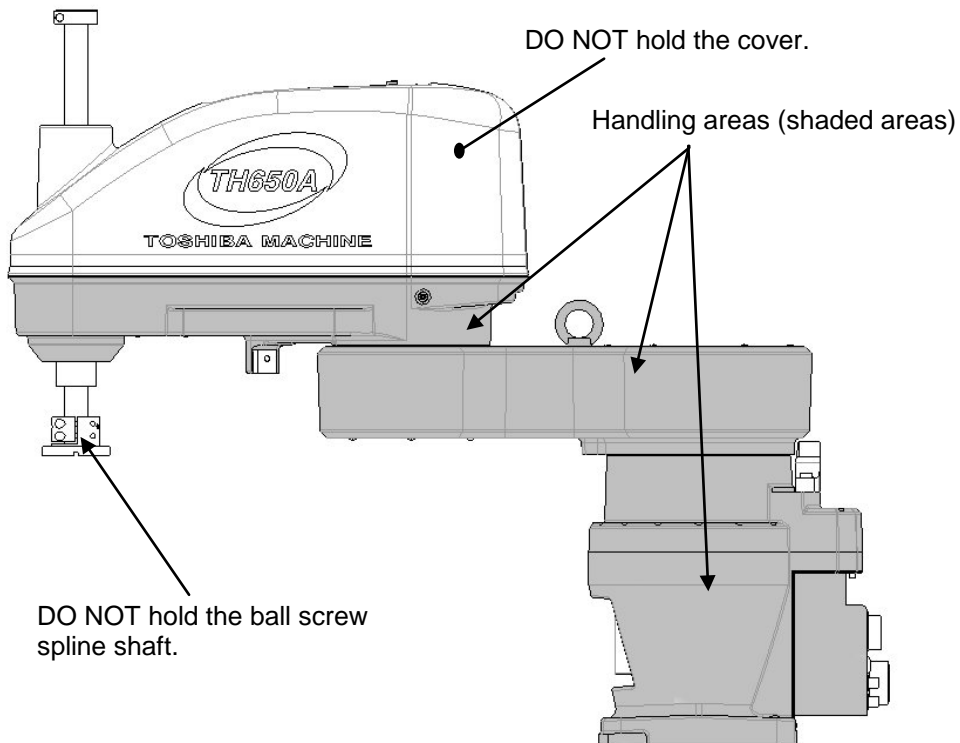

Fig. 2.4 Robot handling areas (shaded areas)

After the installation, remove the clamp and eyebolt used for transport.



CAUTION

- When lifting up the robot by workers, hold the locations (shaded areas) by hands as shown in Fig. 2.4. If the arm 2, cover or ball screw spline shaft is held by hands, an unusually large force is exerted, resulting in a malfunction.
- When carrying the robot by workers, take careful precautions to prevent their hand or leg from being caught in the robot.
- The work should be performed by two (2) or more workers.

2.2.3 Transporting the Controller

Disconnect all cables and teach pendant before transporting the controller.



DANGER

- When placing the controller on the floor, etc., make sure not to have your hands or feet caught.

2.3 Storage

Avoid storing the robot and controller for long periods of time after unpacking them. If this is unavoidable, however, strictly observe the following precautions for storage.

2.3.1 Storage Precautions for the Robot



CAUTION

- Secure the base completely to prevent the robot from falling over. When placed directly on the floor, the robot is unstable and will fall over.
- Keep the robot out of direct sunlight. The timing belts and resin covers may deteriorate.
- Seal the robot in a vinyl bag to prevent rust development and contaminant. Put a desiccant in the bag to absorb moisture. As the tool shaft is susceptible to rust development, coat it with rust-preventive agent or grease the entire tool shaft beforehand.
- Before the use, apply the grease to the tool shaft.
- Before starting an operation, perform running completely.
- During storage, the life of the backup batteries will shorten. It is recommended to replace the batteries at the time of operation.

2.3.2 Storage Precautions for the Controller



CAUTION

- Keep the controller out of direct sunlight. Otherwise, the controller interior will be excessively heated up, causing a trouble.
- Seal the controller in a vinyl bag to prevent rust development and contaminant. Put a desiccant in the bag to absorb moisture.

3. Installation

3.1 Installation Environment

Table 3.1 shows the environmental conditions for the location in which the robot and controller are to be installed.

Table 3.1 Environmental conditions for robot and controller

Item	Specifications
Temperature	In operation : 0 to 40°C In storage : -10 to 50°C
Humidity	20 to 90 % (Non-condensing) DO NOT install the robot where it may be subject to fluids such as water.
Altitude	1000 m or less
Vibration	In operation : 0.98m/s ² or less
Dust	No inductive dust should exist. Consult with Toshiba Machine first if you wish to use the robot and controller in a dusty environment.
Gas	No corrosive or combustible gas should exist.
Sunlight	The robot and controller should not be exposed to direct sunlight.
Power noise	A heavy noise source should not exist nearby.
Magnetic field	A heavy magnetic field source should not exist nearby.



DANGER

- Do not place the robot or controller near combustible. Doing so could lead to fires if it ignites due to a fault, etc.



CAUTION

- In the case where batteries for detecting the motor position are of alkaline type, the batteries can overheat, leak battery fluid, or rupture when used under high temperatures. Also, high temperatures can reduce the performance and lifespan of the battery. If using the robot under high temperatures, please consult with the Toshiba Machine sales office.
- When starting fast-movement operation in low-temperature environment, errors may occur because of the increased torque. In operating the robot in low-temperature environment, start by making low-speed continuous operation for a several minutes to soften the grease before starting high-speed operations.

3.2 Robot Installation

Before installing the robot, you should plan a layout, fully considering the working envelope (or operating range), coordinate system and space for maintenance.

3.2.1 External Dimensions

External view drawing of the robot is shown in Fig. 3.1.

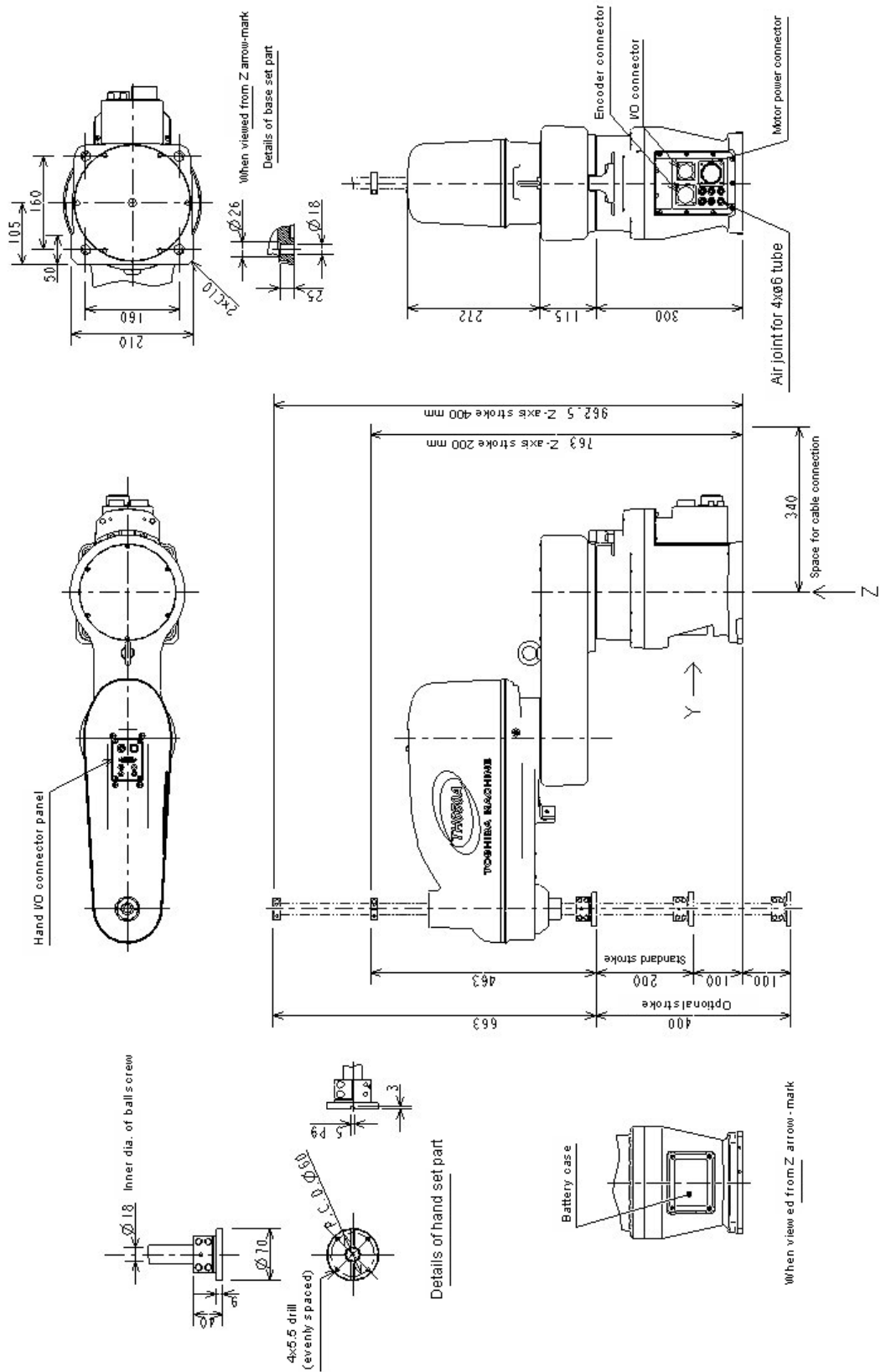

Fig. 3.1 External view

3.2.2 Working Envelope

Fig. 3.2 shows the working envelope of the robot.

Each axis can operate within the working envelope. To prevent the robot from moving out of the working envelope by mis-operation, the robot is equipped with mechanical stoppers outside the working envelope. Additionally, soft limits which can be set by the user are provided. For further information, see the user parameter instruction manual provided separately.

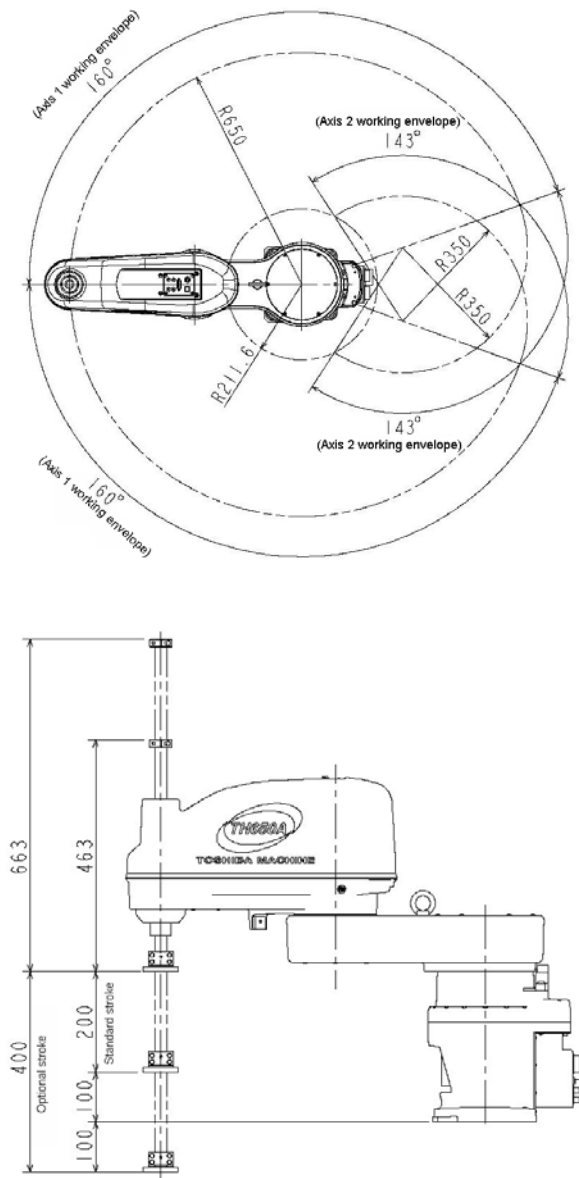

Fig. 3.2 Working envelope

3.2.3 Coordinate System

The robot's joint angle origin (0° or 0 mm position) is factory-calibrated according to the base reference planes. Fig. 3.3 shows the base coordinate system and origin of each axis joint angle.

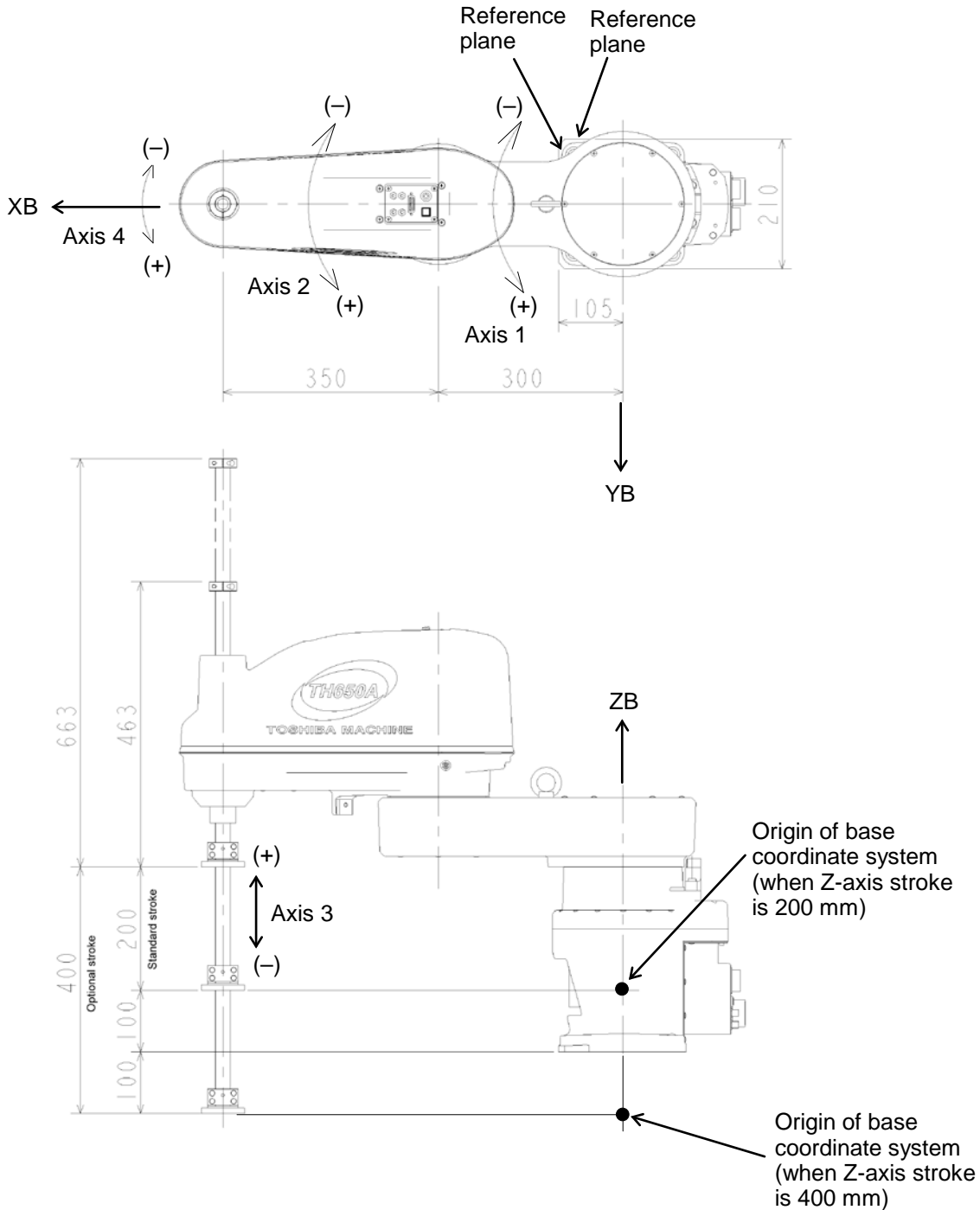



Fig. 3.3 Base coordinate system and joint angle origin

3.2.4 Installing the Robot

The robot is secured, using the set holes on the base (four (4) places). Use M16 hexagon socket head cap screws.

The robot installation method is shown in Fig. 3.4. Reference planes are provided on the base unit.

To align the robot position in the base coordinate system, or to replace the robot, provide adequate reference planes. Then, contact such reference planes to the base reference planes and secure the robot.



CAUTION

- The robot will suddenly accelerate and decelerate during operation. When installing it on a frame, make sure that the frame has sufficient strength and rigidity.
If the robot is installed on a frame that does not have sufficient rigidity, vibration will occur while the robot is operating, and could lead to faults.
When installing the robot on the floor, secure the robot with anchor bolts, etc.
- Install the robot on a level place. Failure to do so could lead to a drop in performance or faults.

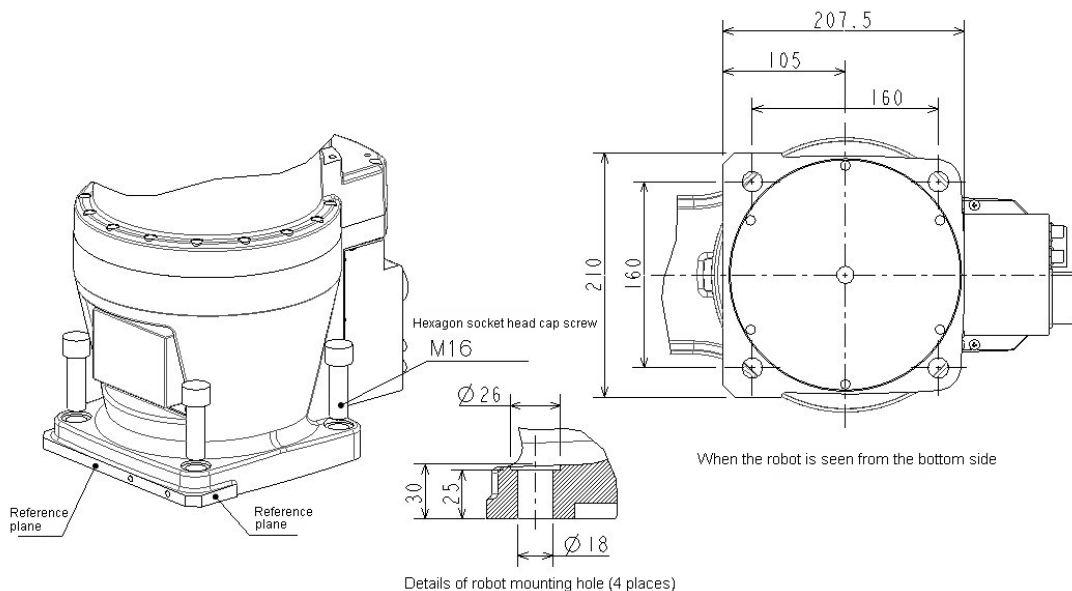

Fig. 3.4 Setting method

3.3 Installing the Controller

3.3.1 External Dimensions

External view of the controller is shown in Fig. 3.5.

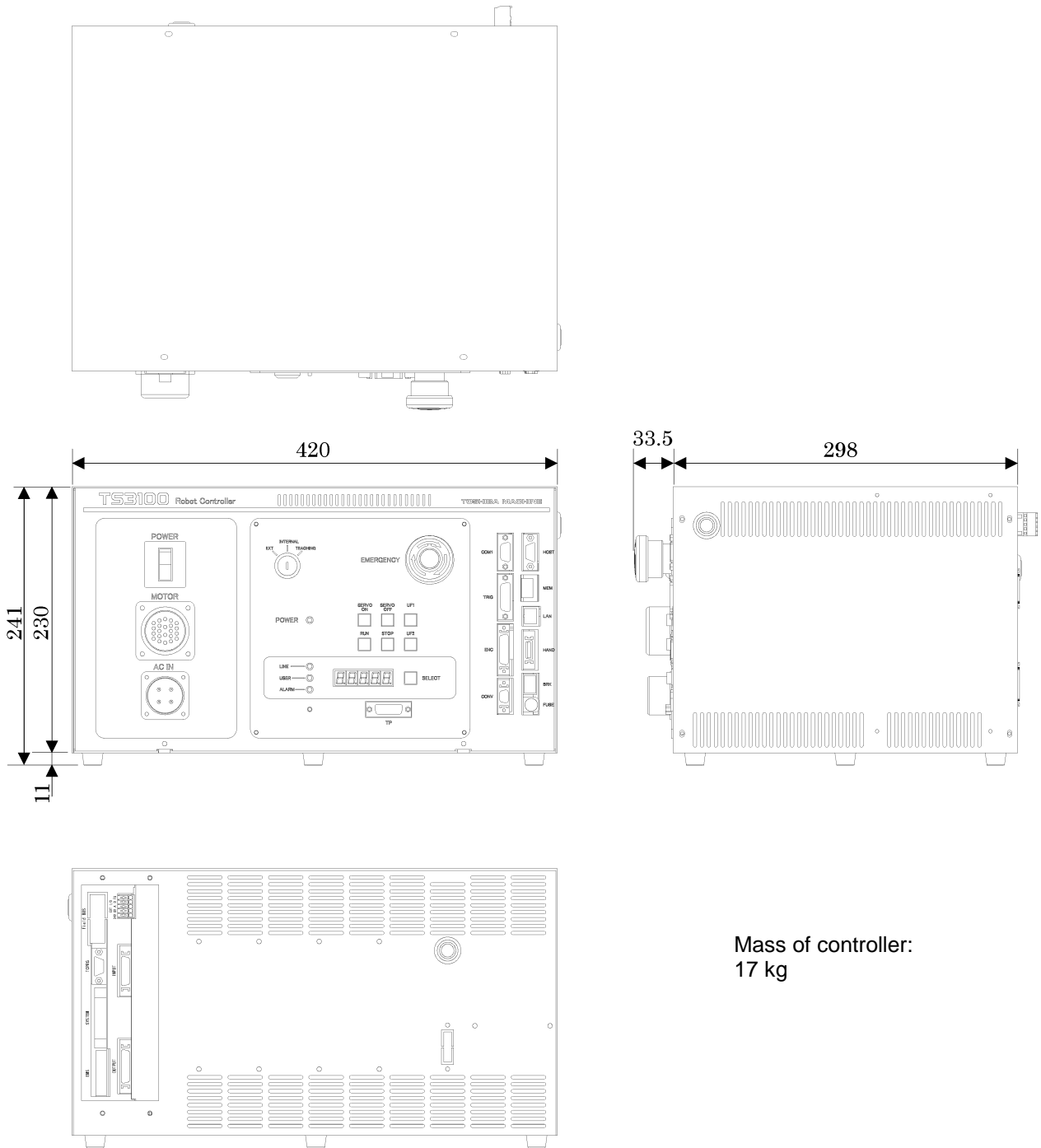



Fig. 3.5 External view of controller

3.3.2 Precautions for Direct Installation

It is necessary to provide a clearance of 50 mm or more in the horizontal direction and a clearance of 100 mm or more in the upward direction near the controller.

When installing the controller lengthwise, be sure to locate the right lateral side for sideways installation at the bottom side. (The lengthwise installation is an option.)



CAUTION

- Provide a ventilation space at the side of the controller so that the air vent holes are not blocked. The space equal to the length of the legs should be kept below the lower surface.
Failure to do so could cause the cooling performance to drop or to faults.
- DO NOT stack the controllers.
- DO NOT place any object on top of the controller.

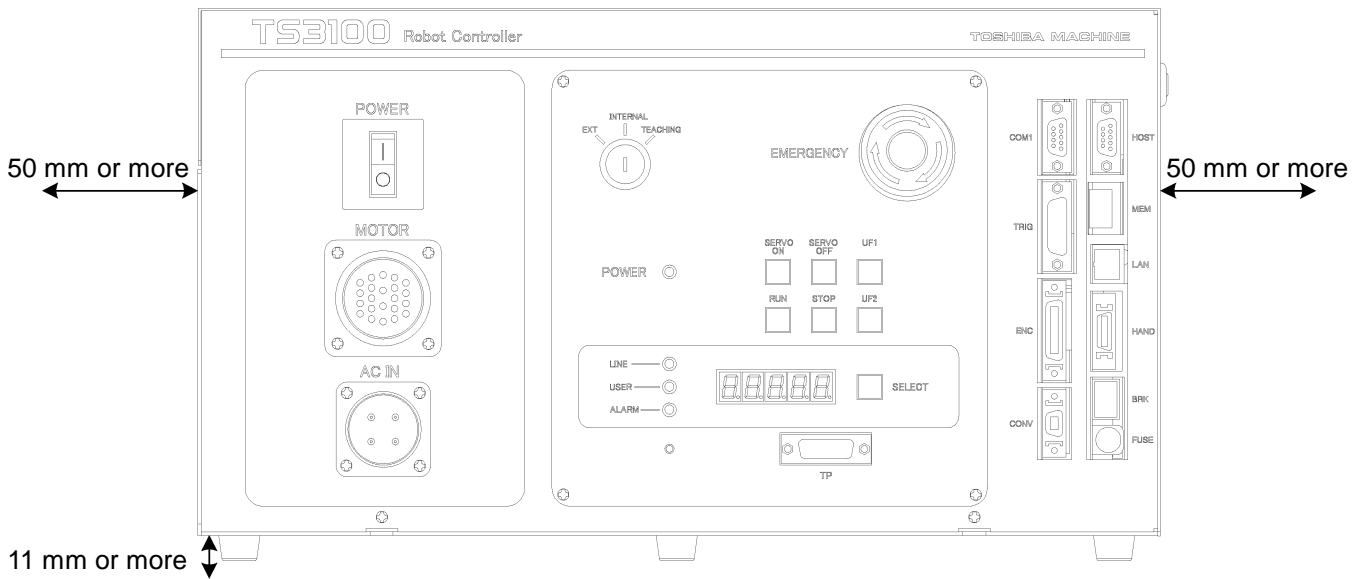

Fig. 3.6 Controller ventilation space

↑↓ 11mm

3.3.3 Rack Mounting Dimensions

When mounting the robot controller in a rack, set the side brackets using the screw holes provided on both ends of the front panel, and secure the controller to the rack. The side brackets [1] in Fig. 3.7 are optional.

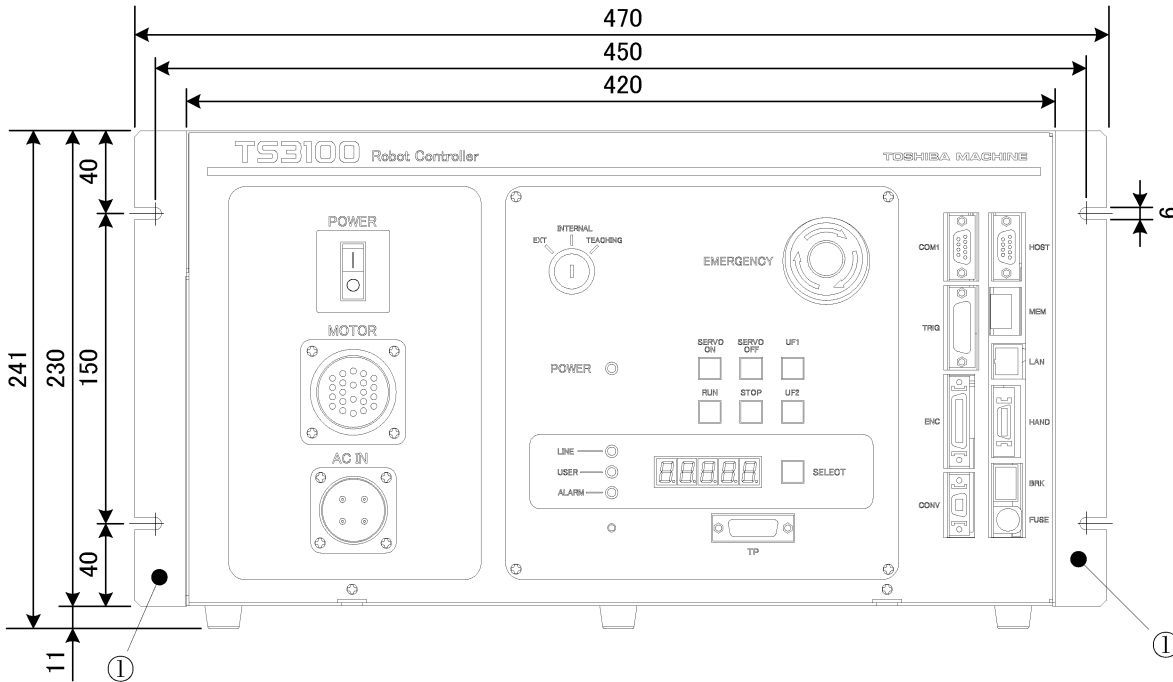



Fig. 3.7 Screw hole dimensions for securing controller

3.3.4 Precautions for Rack Mounting

Pay attention to the following matters when rack-mounting the robot controller.

- a) When mounting the robot controller in a rack, use the screw holes provided on both ends of the front panel, and secure the controller. (Optional side brackets are required.)



CAUTION

- If the rack is completely sealed, provide holes to allow the air to be let out, force-ventilate the rack with a fan, or cool it indirectly so that the heat will not be trapped in the rack.
If the heat is trapped in the rack or controller, faults could occur.

- b) As the cable connectors are connected to the rear side of the controller, provide a space of 110 mm on the rear side.

For maintenance, the upper cover should be removed. (See Fig. 3.8.)

Keep this in mind when installing the controller. At maintenance, the controller should be removed from the rack. Specifically, be careful of the following points.

- 1) Arrange the cables around the rear side of the controller (so that the controller can be removed).
- 2) Arrange the cables between the controller and control panel when the control panel is separated.
- 3) Connect all cables in such a manner that the robot can be operated even if the controller is removed from the rack.

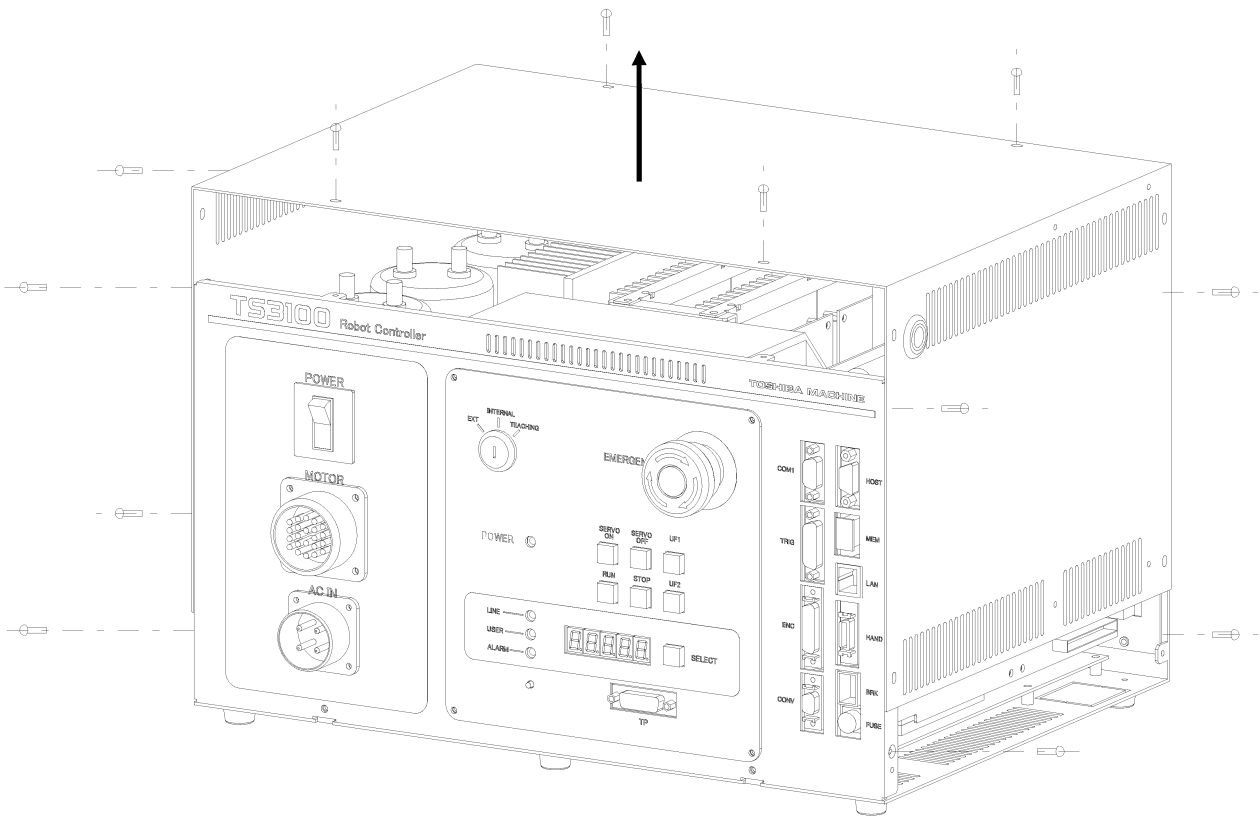

Fig. 3.8 Removing upper cover

- c) When the controller is mounted on the rack, the weight of the controller should be supported with the legs of the controller. Screw holes for rack-mounting the controller are used for securing the controller panel, and the weight of the controller cannot be supported only with these screws.
- d) On the front of the controller, a clearance of approx. 90 mm should be provided for connecting the connector of the teach pendant. Even if the teach pendant is not used, a clearance of approx. 60 mm is required for connecting a dummy plug.

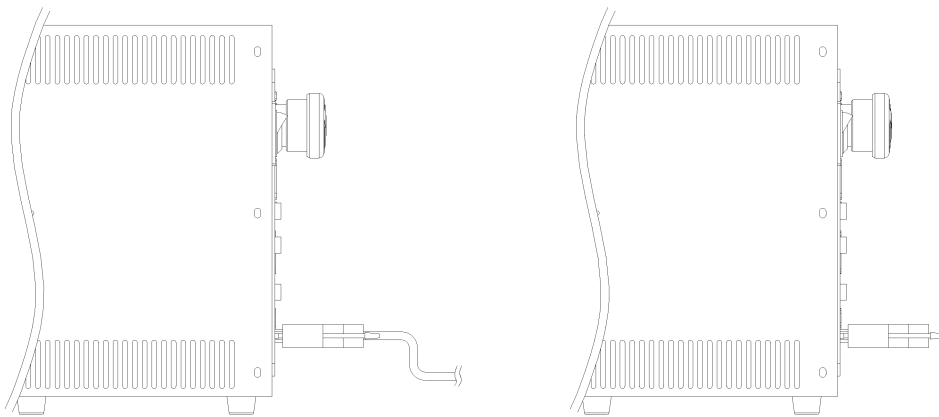

Fig. 3.9 Clearance of controller front side

3.4 Precautions for Handling the Teach Pendant

Be careful of the following matters when handling the teach pendant.



CAUTION

- DO NOT drop the teach pendant or hit it against anything.
- DO NOT pull the cable running from the teach pendant.
- DO NOT press the switches on the teach pendant with anything sharp (like the tip of a knife, pencil, ball-point pen, etc.).
- DO NOT place or use the teach pendant near open flames.
- DO NOT leave the teach pendant in direct sunlight for a long period of time.

3.5 Safety Measures

- a) When installing the robot, provide sufficient space to carry out the work safely.
- b) Clarify the hazard zone, and provide a safety fence so that other persons cannot enter the zone easily. The hazard zone is the zone near the robot's working space where a hazardous state could occur if a person enters.
- c) Provide limit switches, photo switches, foot switch, etc., at the entrance of the safety fence to provide an emergency stop function that will stop the robot if a person enters the hazard zone. The emergency stop function should be an electrically independent normal close contact (closed in normal operation) with compulsive opening function and must not be automatically recovered.

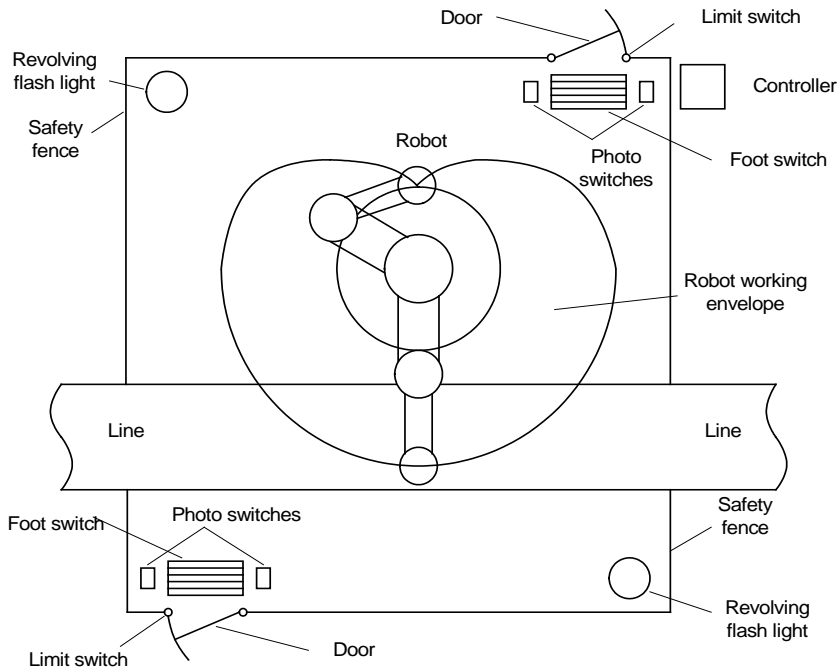

- d) The controller should be installed at a place outside the hazard zone where the operator can view the robot movement.

4. System Connections

4.1 Cable Wiring

This section describes the various types of cables and connectors and explains how these are to be connected.

4.1.1 Connector Arrangement on the Controller

The cables connected to the robot controller are shown in Fig. 4.1.

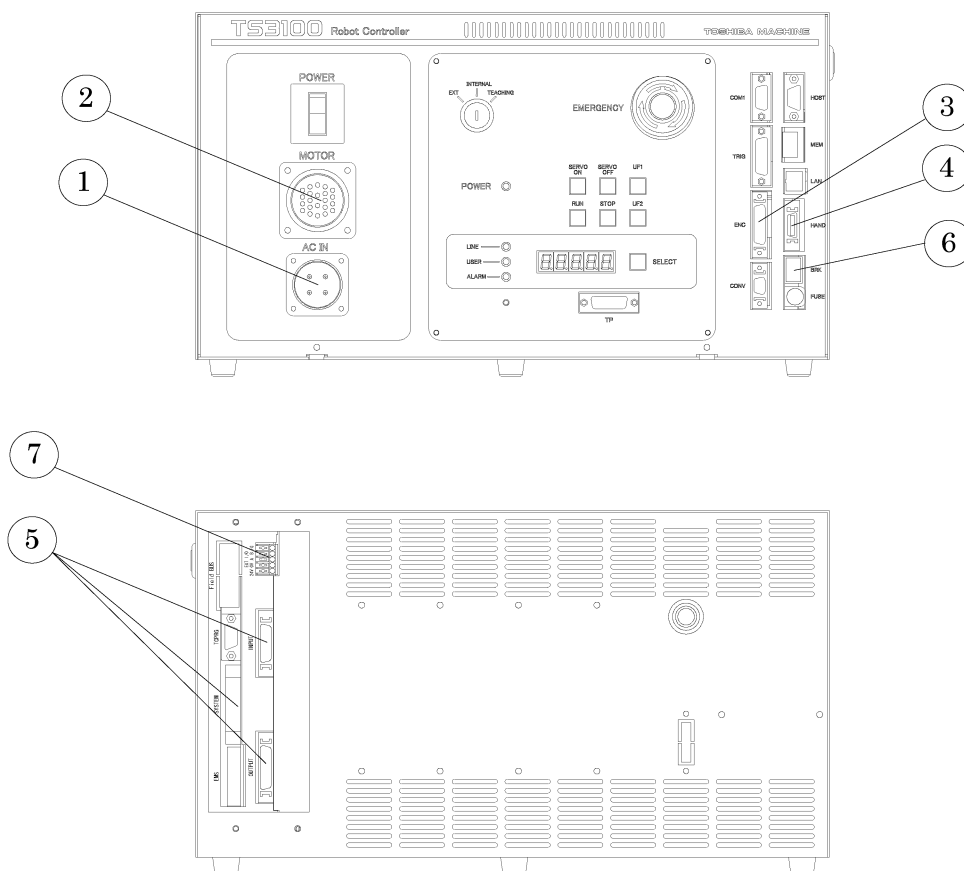

Fig. 4.1 Robot controller connector arrangement

- ① Power cable (ACIN)
- ② Motor cable (MOTOR)
- ③ Encoder cable (ENC)
- ④ Robot control signal cable (HAND)
- ⑤ External operation input signal cables (SYSTEM, INPUT, OUTPUT)
- ⑥ Brake signal cable (BRK)
- ⑦ Distribution I/O cable (EXT-I/O)

In the subsequent paragraphs, we explain how to connect cables ① to ④ inclusive. For information on how to connect cables ⑤, ⑥ and ⑦, refer to the Interface Manual.

4.1.2 Connecting the Power Cable “CN1”

([1] of Fig. 4.1; plug connector attached)

The power cable is used to supply the main AC power to the controller.

Table 4.1 Power supply specifications

Item	Specifications
Power supply	Single phase, AC 200 ~ 240 V, 50/60 Hz \pm 1 Hz
Power capacity	3.5 kVA
Instantaneous power failure	Within 40 msec
Grounding	Grounding with grounding resistance of 100 Ω or less

The connector is ACIN (① of Fig. 4.1).

ACIN plug connector	Type: JL04V-6A22-22SE-EB-R	Maker: Japan Aviation Electronics Industry
ACIN cable clamp	Type: JL04-2022CK (14)-R	Maker: Japan Aviation Electronics Industry
Wire	3.5 mm ² ~ 5.5 mm ²	

As the cable is not an accessory, use the attached plug connector connected to ACIN on the controller side to manufacture a cable.

Wires are to be soldered to the connector.



DANGER

- Be sure to use the designated wire. Failure to do so could lead to fires or faults.
- When connecting the connector and wires, make sure not to mistake the terminal arrangement.
- After making the connection, use a tester, etc., to confirm the connection.

For the terminal arrangement, see Para. 4.1.7.



CAUTION

- Unless the main power is normally supplied to the controller due to phase defect or voltage drop, an error of “8-027 Slow Charge error” occurs. When this happens, make sure that the maser power voltage at the controller power connector satisfies the specified input power of the controller, and that the same voltage is stabilized.
- For details of the 8-027 error, see Para. 13.7 of the Operator’s Manual.

4.1.3 Connecting the Motor Cable “MOTOR” (② of Fig. 4.1) (Cable attached)

The motor cable connects the controller and robot, and supplies the power required to rotate the motor from the controller servo driver to each axis feed motor of the robot. The connector for connecting the motor cable is MOTOR (② of Fig. 4.1). Location of the motor cable on the robot side is ① in Fig. 4.2.

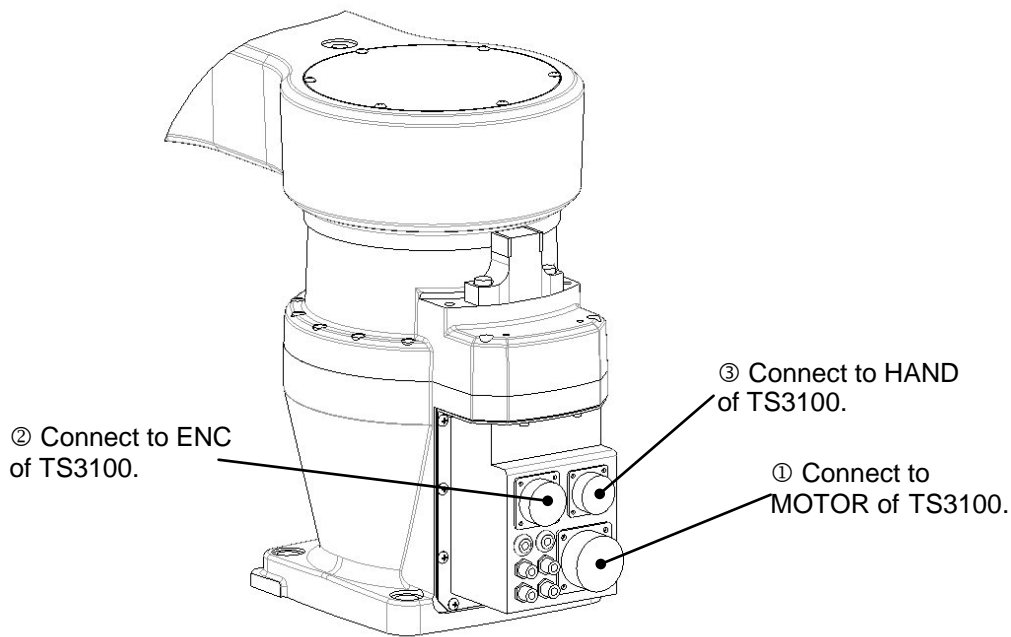

Fig. 4.2 Robot side connector arrangement

4.1.4 Connecting the Encoder Cable “ENC” (③ of Fig. 4.1) (Cable attached)

The encoder cable is a signal line used to transmit a signal from the rotation angle detecting encoder of each robot axis to the controller.

The connector for connecting the encoder cable is ENC (③ of Fig. 4.1). Location of the encoder cable on the robot side is ② in Fig. 4.2.

4.1.5 Connecting the Robot Control Signal Cable “HAND” (④ of Fig. 4.1) (Cable: option)

The robot control signal cable is used for motor brake ON and OFF, and input and output of robot control signals such as hand operation signal.

The connector for connecting the robot control signal cable is HAND (④ of Fig. 4.1).

Location of the robot control signal cable connector on the robot side is ③ in Fig. 4.2.

4.1.6 Connecting and Disconnecting Cables

 **CAUTION**

- Before connecting or disconnecting any controller cable, be sure to turn off the main power (“POWER”) switch.
- When disconnecting a cable, be sure to pull the plug and not the cord. Otherwise, you may damage the cable.

a) Circular connectors: ACIN, MOTOR

Firstly align the key position, and completely insert the connector on the cable side into the controller connector. Then turn the cable side lock screw to the right to clamp the cable. A loose screw can cause a contact failure or other accident. To avoid this, make sure that the screw is clamped completely. To disconnect the connectors, turn the lock screw to the left and pull out the cable side connector.

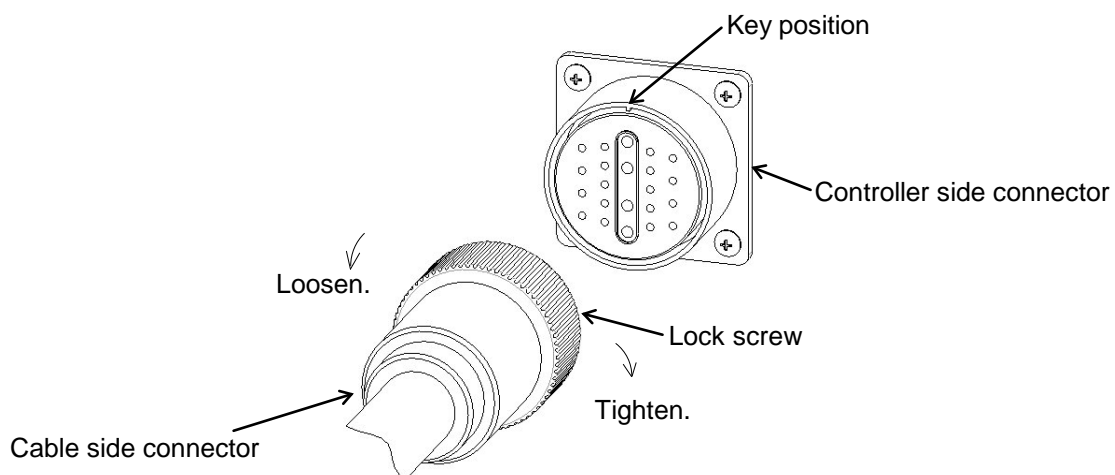

Fig. 4.3 Connecting and disconnecting a circular connector

- b) Square connectors: ENC, HAND, SYSTEM, INPUT, OUTPUT, TRIG, CONV
Firstly, completely insert the cable side connector into the controller connector.
Then tighten the lock screws on both ends of the cable side connector with a screwdriver. A loose screw can cause a contact failure or other accident. To avoid this, make sure that the screws are clamped completely. To disconnect the connectors, first loosen the lock screws, then pull out the cable side connector. INPUT and OUTPUT are quick-operated lock type connectors, however.

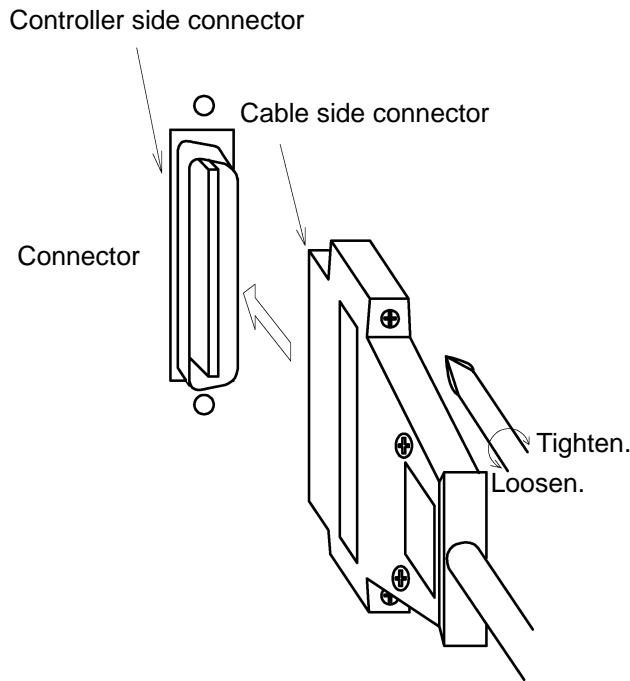
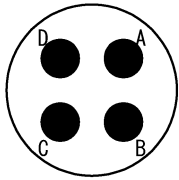

Fig. 4.4 Connecting and disconnecting a square connector

4.1.7 Examples of Connector Terminal Arrangement

a) Power cable connector ACIN



Connects to controller.

Type: JL04HV-2E22-2
2PE-B

Manufacturer: Japan Aviation Electronics Industry

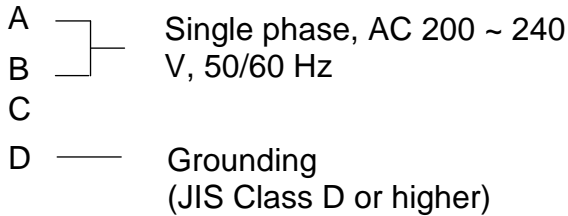

DANGER

- Completely connect the grounding cable. Otherwise, an electric shock or fire may be caused if a fault or electric leak occurred. Or mis-operation may be caused by noise.

b) Motor cable connector MOTOR

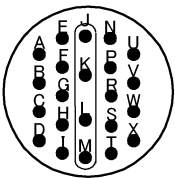

Connects to controller.

Type: JL04V-2A28-11SE

Manufacturer: Japan Aviation Electronics Industry

c) Encoder cable connector ENC

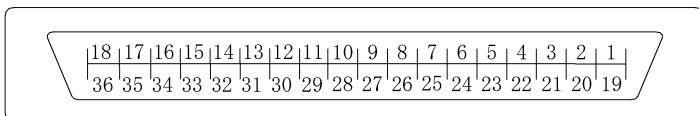

Connects to controller.

Type: 52986-3659

Manufacturer: MOLEX

d) Robot control signal cable connector HAND

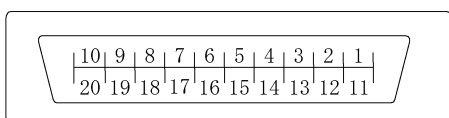

Connects to controller.

Type: 52986-2079

Manufacturer: MOLEX

e) Universal input signal cable connector INPUT

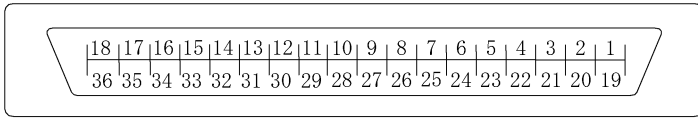

Connects to controller.

Type: DHA-RC36-R132N-FA

Manufacturer: DDK, Ltd.

f) Universal output signal cable connector OUTPUT

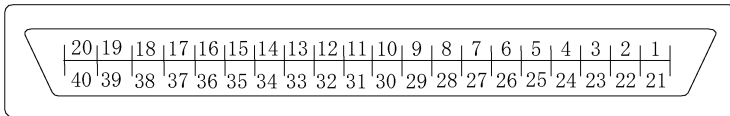

Connects to controller.

Type: DHA-RC40-R132N-FA

Manufacturer: DDK, Ltd.

g) System input/output signal cable connector SYSTEM

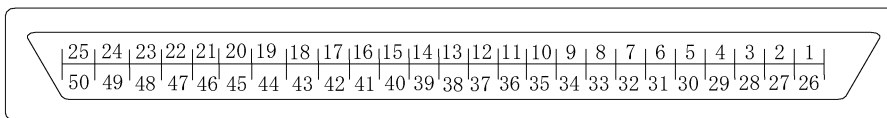

Connects to controller.

Type: 52986-5079

Manufacturer: Molex

h) Trigger input connector TRIG

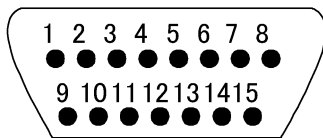

Connects to controller.

Type: XM2C-1542-112L

Manufacturer: OMRON

i) Encoder cable connector CONV

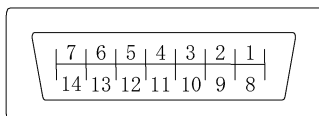

Connects to controller.

Type: 52986-1479

Manufacturer: Molex

- j) Emergency stop, safety input, and external P24V supply connector EMS

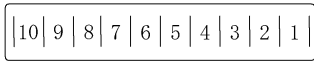

Connects to controller.

Type: ML-4000CWJH-10PGY

Manufacturer: SATO PARTS

- k) Brake connector BRK

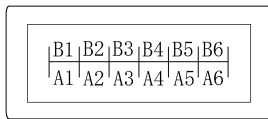

Connects to controller.

Type: 1-1827876-6

Manufacturer: TYCO ELECTRONICS AMP

4.2 Controller Connector Signals

4.2.1 Connector Signal Connection Diagrams

Diagrams showing which signals correspond to which terminals are shown in Section 2 of the Interface Manual.

4.2.2 Jumpers for Safety Related Signals

The following system input signals are provided to serve for the safety purpose.

System input signals	SYSTEM-12	(STOP)
	SYSTEM-16	(SVOFF)
	SYSTEM-14	(BREAK)
	EMS-7, 8	(EMS2B ~ EMS2C)
	EMS-9, 10	(EMS1B ~ EMS1C)
	EMS-3, 4	(ENA2B ~ ENA2C)
	EMA-5, 6	(ENA1B ~ ENA1C)

These signals are already jumpered for the connectors provided for the TS3100 robot controller. If you wish to use or change them, therefore, you should remove the jumpers and rewire as appropriate. If you plan to use the robot without using system input signals, be sure to connect the attached connectors to the controller side SYSTEM, EMS connectors.

Unless the following signals are used as the system signals, jumper them also.

SYSTEM-15	(LOW_SPD)
SYSTEM-13	(CYCLE)

Connector jumpers

SYSTEM		EMS	
12-17(18)	14-17(18)	3-4	5-6
16-17(18)	(13-17(18))	7-8	9-10
(15-17(18))	-		



CAUTION

- Unless the signals of SVOFF and emergency stop contacts 1, 2 are jumpered, the controller servo power cannot be turned on.
- Unless the CYCLE signal is jumpered, the controller enters the cycle operation mode.
- Unless the LOW_SPD signal is jumpered, the robot is operated at low speed during automatic operation.
- Unless the STOP signal is jumpered, automatic operation of the robot is not possible.
- Unless the BREAK signal is jumpered, automatic operation of the robot is not possible.

4.3 Separating Control Panel from Controller

4.3.1 Removing Control Panel

Remove the control panel in the following manner.

- a) Loosen the four (4) screws at the four (4) corners, which secure the control panel.
- b) Remove these screws, then carefully draw out the control panel toward your side.

Caution: Be careful of the cable connected on the rear side.

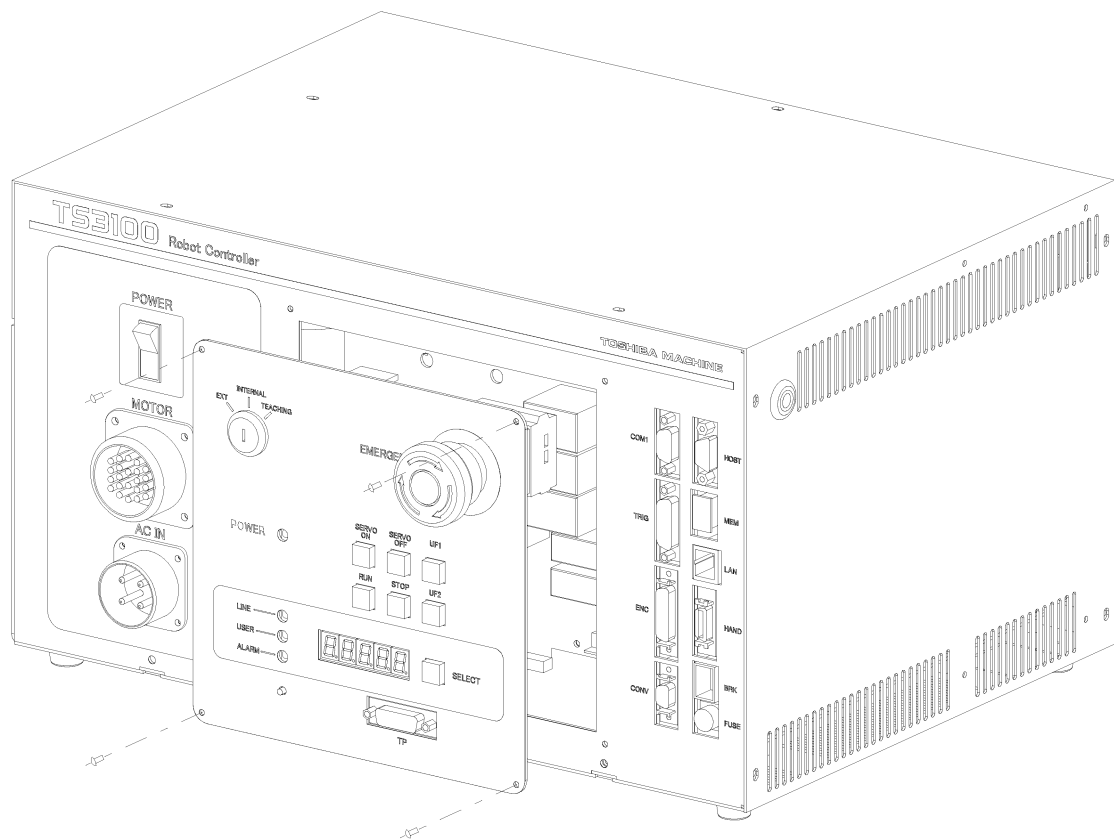

Fig. 4.5 Removing control panel

4.3.2 Cable between Controller and Control Panel

The cable required to connect the control panel and controller when they are installed separately can be provided optionally.

4.3.3 Control Panel Mounting Dimensions

The dimensions of mounting the control panel are shown in Fig. 4.6.
 Cross truss head screws ($\varnothing 3 \times 6$, ZN3-B) are used.

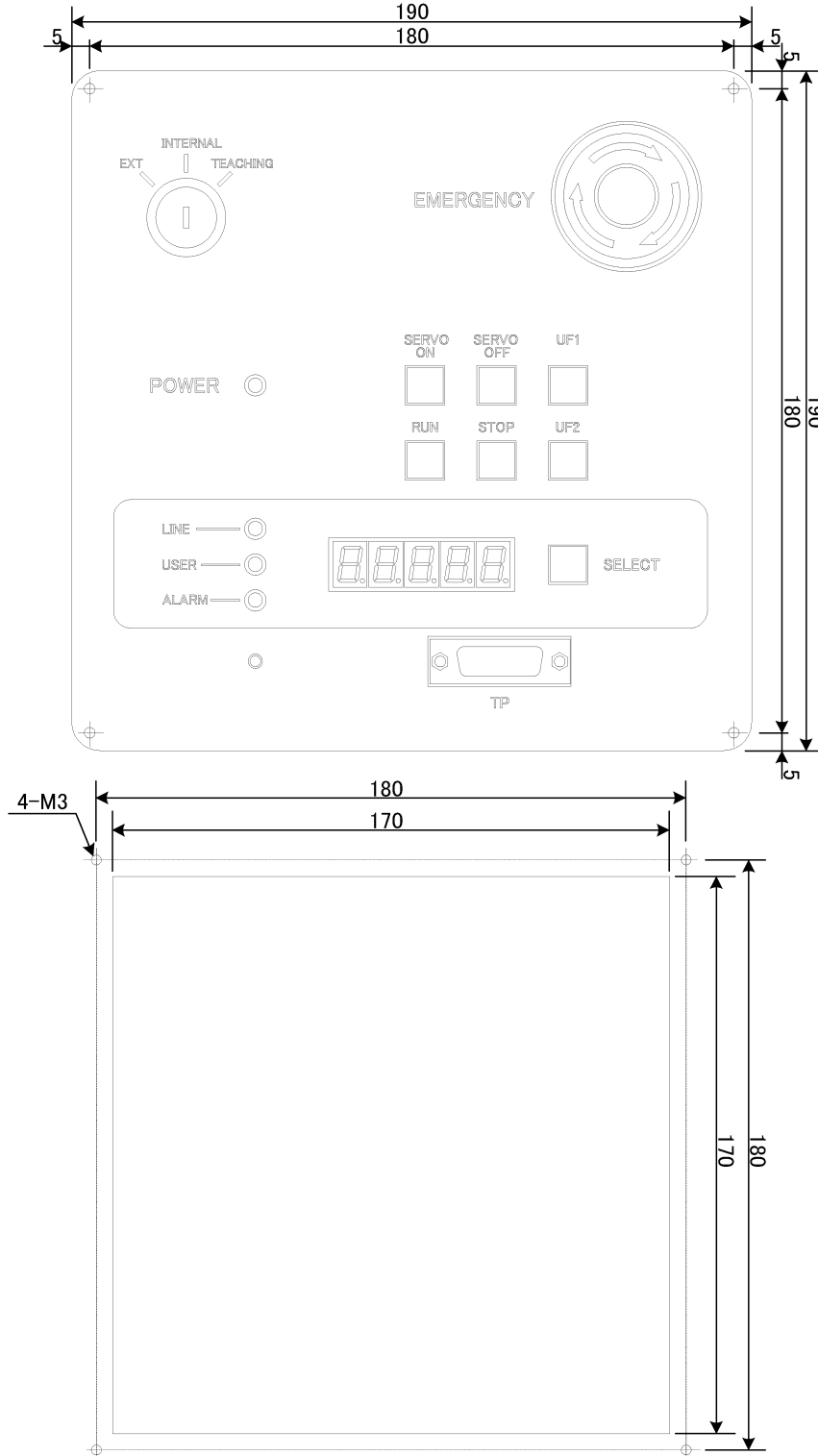

Fig. 4.6 Control panel mounting dimensions

4.3.4 Mounting Dummy Panel on Controller

When the control panel has been disengaged from the controller, mount a dummy panel on the place where the control panel was set before, as shown in Fig. 4.7. The dummy panel, set parts, etc. are provided optionally.

- a) Connect the cable connector which was disconnected when separating the controller from the control panel, to the rear side of the dummy panel, then screw both ends of the connector. When mounting the connector, use the cross truss screws ($\phi 3 \times 6$, ZN3-B).
- b) Screw the dummy panel into the controller.

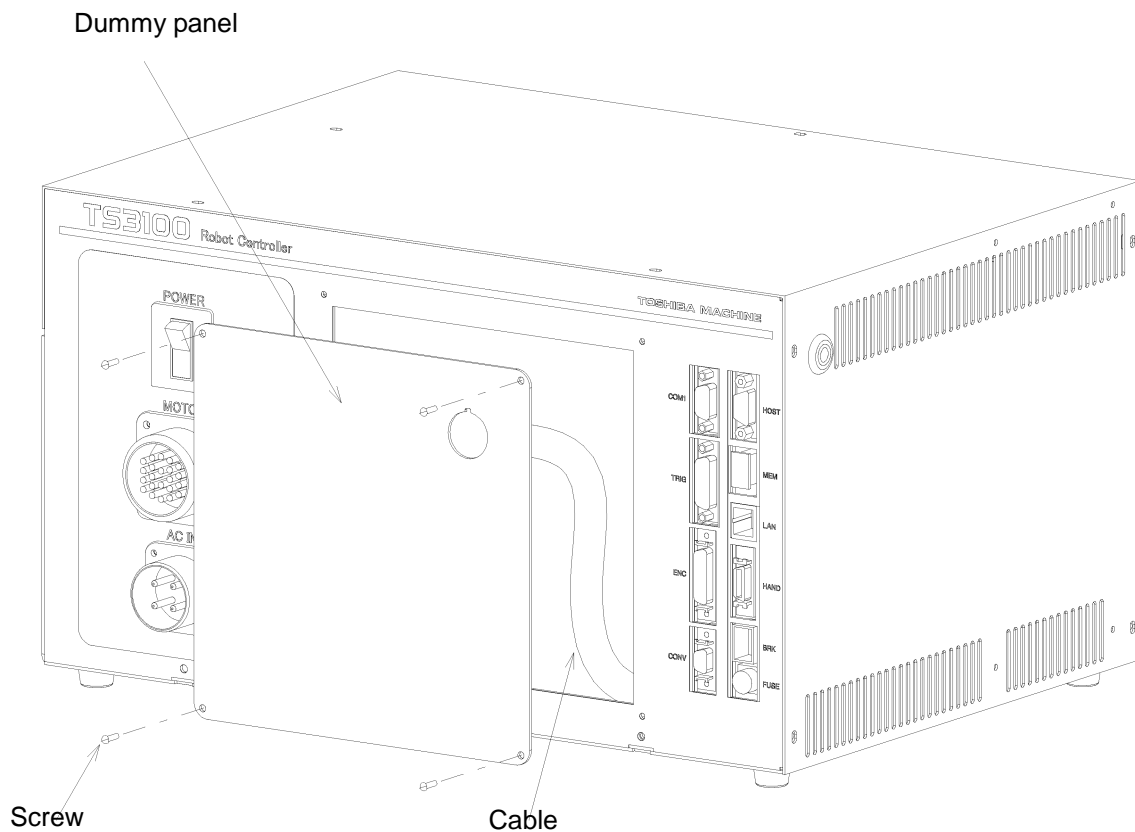

Fig. 4.7 Mounting dummy panel

4.3.5 Dimensions when Separating Control Panel

Fig. 4.8 shows the connections of the control panel and dummy panel. Provide a clearance of 50 mm or more (with cover, 60 mm or more) on the rear side of the separated control panel.

When the cable is connected to the dummy panel of the controller, provide a clearance of 80 mm or so in front of the controller as the cable connector sticks out of the panel surface.

Without cover: 50 mm or more
With cover: 60 mm or more

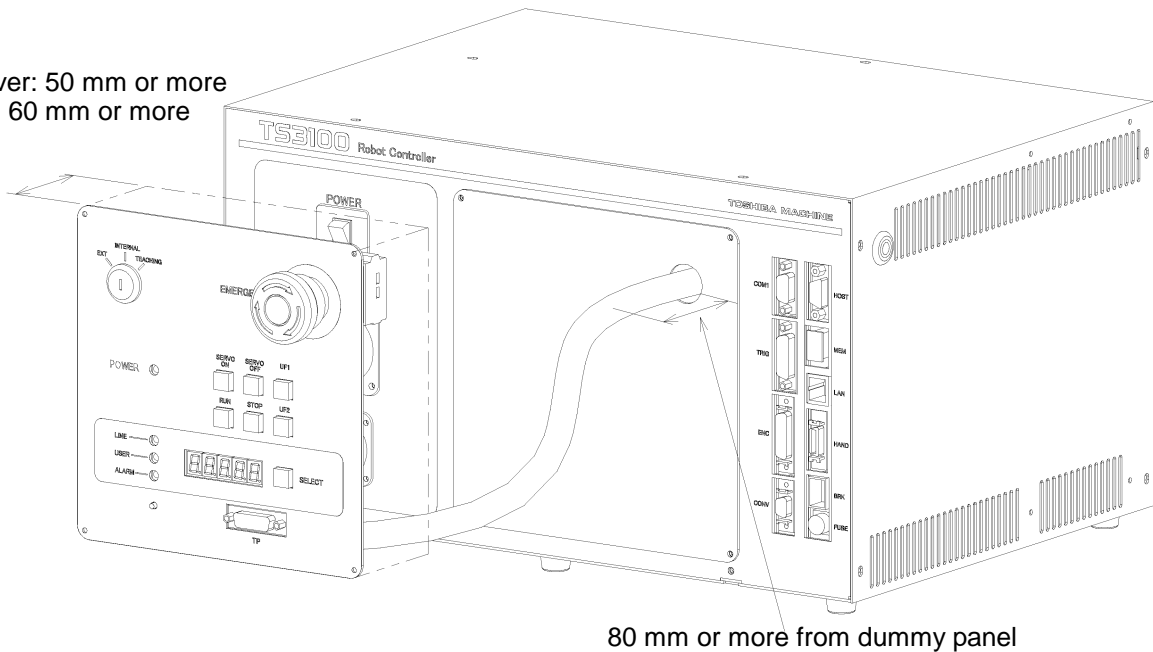

Fig. 4.8 Cable connections of dummy panel and control panel

5. Tool Interface

5.1 Mounting Tool

The tool is mounted on the end of the tool shaft. Dimensions of the tool shaft section are shown in Fig. 5.1.

As shown in Fig. 5.1, the tool is centered with the $\varnothing 20H7$ mating section. The tool direction is adjusted by means of the 5×5 keys and secured with four (4) M5 bolts.

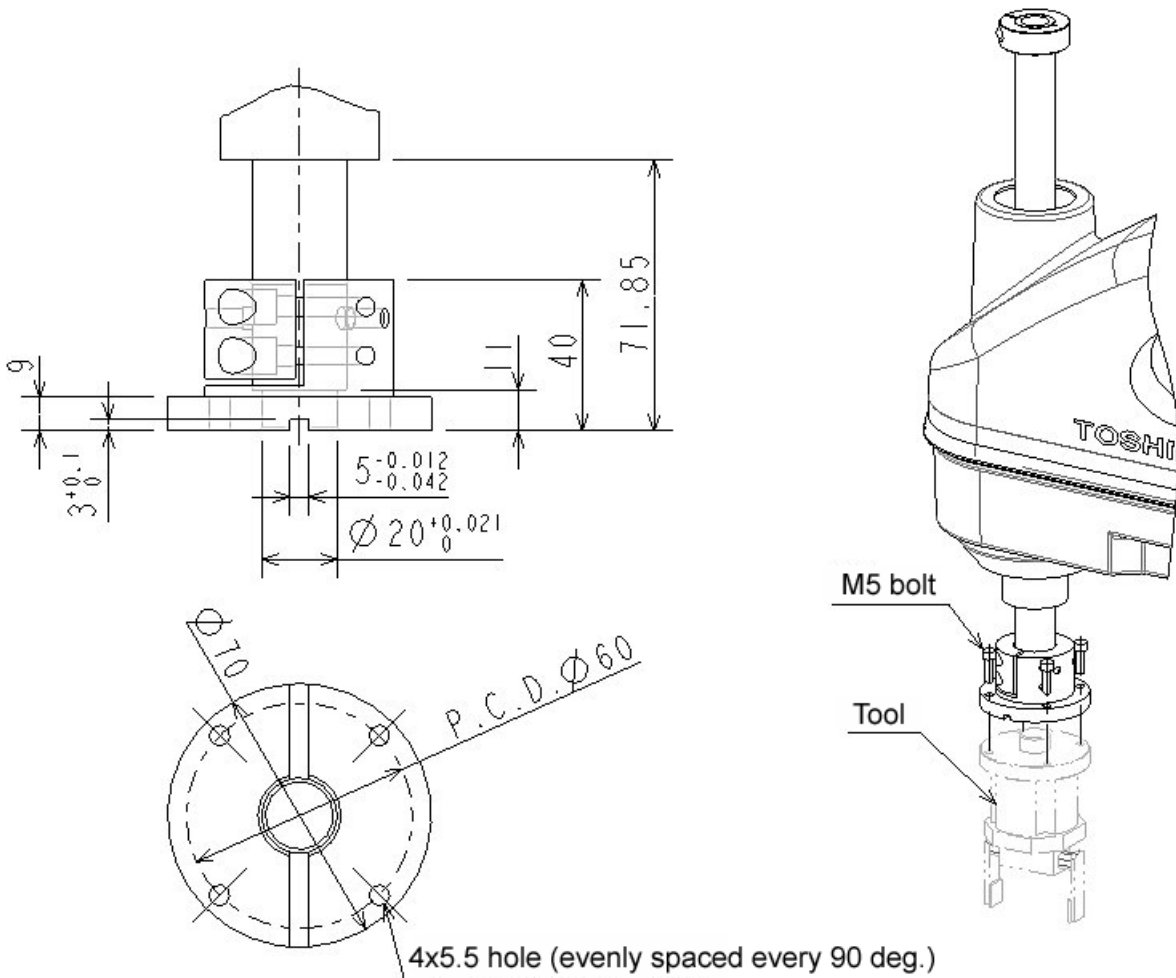

Fig. 5.1 Tool mounting dimensions

5.2 Tool Wiring and Piping

The robot is provided with wiring and air piping for the tool. These wiring and piping extend to the arm 2 and are used as follows:

5.2.1 Tool Signals (Controller Side)

The controller is provided with the tool signals of eight input signals for sensors, eight control signals for solenoid valves, DC24 V (P24V) signal, and DC24 V GND (P24G) signal. The signals enable connection from the controller to external equipment.

a-1) Input signal connector HAND (Type-N)

Pin	Signal name		Signal No.	Input circuit and example of connections
1	D-IN0	Input signal 0	201	
2	D-IN1	Input signal 1	202	
3	D-IN2	Input signal 2	203	
4	D-IN3	Input signal 3	204	
5	D-IN4	Input signal 4	205	
6	D-IN5	Input signal 5	206	
7	D-IN6	Input signal 6	207	
8	D-IN7	Input signal 7	208	
19	P24G	0 V		
20	–	–		

a-2) Input signal connector HAND (Type-P)

Pin	Signal name		Signal No.	Input circuit and example of connections
1	D-IN0	Input signal 0	201	
2	D-IN1	Input signal 1	202	
3	D-IN2	Input signal 2	203	
4	D-IN3	Input signal 3	204	
5	D-IN4	Input signal 4	205	
6	D-IN5	Input signal 5	206	
7	D-IN6	Input signal 6	207	
8	D-IN7	Input signal 7	208	
19	P24V		DC24 V power	
20	–	–		

As input signals, no-voltage contacts or transistor open collector inputs are used.

No-voltage contact specifications:

Contact rating: DC24 V, 10 mA or over (circuit current: approx. 7 mA)

Minimum contact current: DC24 V, 1 mA

Contact impedance: 100 Ω or less

Transistor specifications:

Withhold voltage between collector and emitter: 30 V or over

Current between collector and emitter: 10 mA or over (circuit current: approx. 7 mA)

Leak current between collector and emitter: 100 μA or less

b-1) Output signal connector HAND (Type-N)

Pin	Signal name		Signal No.	Input circuit and example of connections
9	D-OUT0	Output signal 0	201	
10	D-OUT1	Output signal 1	202	
11	D-OUT2	Output signal 2	203	
12	D-OUT3	Output signal 3	204	
13	D-OUT4	Output signal 4	205	
14	D-OUT5	Output signal 5	206	
15	D-OUT6	Output signal 6	207	
16	D-OUT7	Output signal 7	208	
17	P24V		DC24 V power	
18				

b-2) Output signal connector HAND (Type-P)

Pin	Signal name		Signal No.	Input circuit and example of connections
9	D-OUT0	Output signal 0	201	
10	D-OUT1	Output signal 1	202	
11	D-OUT2	Output signal 2	203	
12	D-OUT3	Output signal 3	204	
13	D-OUT4	Output signal 4	205	
14	D-OUT5	Output signal 5	206	
15	D-OUT6	Output signal 6	207	
16	D-OUT7	Output signal 7	208	
17	P24G	0 V		
18				

By using the P24V power of the controller, a relay, solenoid valve, etc., can be driven. When the external power is used, GND of the external power should be common to GND (P24G) of the robot controller.

Output specifications:

- Rated voltage : DC24 V (P24V)
- Rated current : 100 mA

- When a relay or solenoid valve, etc., is connected, it is necessary to use a surge killer or diode to absorb the surge voltage.
 - When a double solenoid is used, HO_1 and HO_2, and HO_3 and HO_4 are used as pairs.

The right figure shows the DC relay circuit when the external power is used.

5.2.2 Tool Wiring

Five (5) input signals are provided for sensors, etc. and four (4) control signals for solenoid valves, etc. A supply power signal of P24V is also provided. They are connected to the controller. The wiring arrangement for these cables is shown in Fig. 5.2. The wires are connected to the connectors on the upper side of the arm 2. The user should provide the following connectors to connect the cables.

D-SUB connector (standard)	Type:
	<Hood> XM2S-1511 (Maker: OMRON)
	<Basic body> XM2A-1501 (Maker: OMRON)
Cannon connector (option)	Type: MS3106B-20-29-S (Maker: DDK Ltd.)
Adaptive cable	Conductive cross section area: 0.2 mm ² ~ 0.5 mm ²

Each connector and cable are connected by soldering.



DANGER

- Be sure to use the designated wire. Otherwise, fires or faults may be caused.
- When connecting the connector and wires, make sure not to mistake the terminal arrangement.
- After making the connection, use a tester, etc., to confirm the connection.

When controlling the robot from the sequencer (i.e., programmable ladder controller: PLC), etc. installed separately, remove the motor cover from the base section, remove connectors **JOES** and **JOFS** on the rear side, then connect the cables running from the PLC, etc. through the cable inlets provided on the motor cover. (See Fig. 5.2.) For ahead of the **JOES** and **JOFS** connectors, the user should prepare the following plug connectors and connect the cables. The current is 1 A or less per cable.

Type of connector:	JOES	SMP-07V-BC (Maker: J.S.T. Mfg.)
	JOFS	SMP-06V-BC (Maker: J.S.T. Mfg.)
Type of contact:	BHF-001T-0.8SS (Maker: J.S.T. Mfg.)	
Adaptive cable	Conductive cross section area: 0.2 mm ² ~ 0.5 mm ²	

Opposite connector type

Type of connector:	JOEP	SMR-07V-B (Maker: J.S.T. Mfg.)
	JOFP	SMR-06V-B (Maker: J.S.T. Mfg.)
Type of contact:	BYM-001T-0.6 (Maker: J.S.T. Mfg.)	

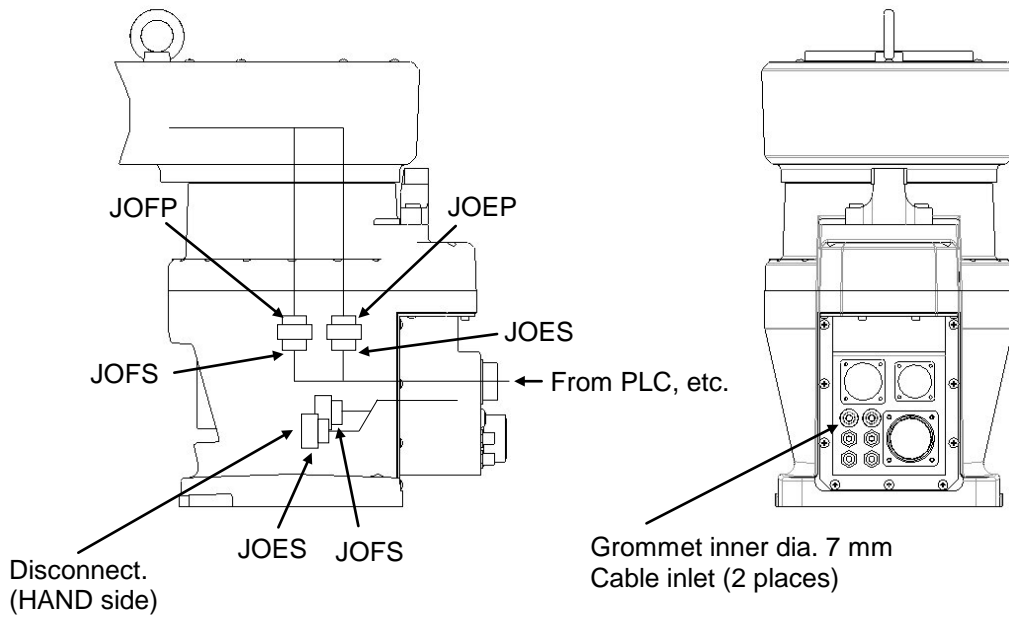

Fig. 5.2 Wiring to PLC, etc.

Input/output signal connector CN0 (Type-N)

Pin (D-SUB)	Pin (Cannon)	Signal name		Signal No.	Input/output circuit and example of connections
	A	Not used			
	B	Not used			
	C	Not used			
3	D	D-IN0	Input signal 0	201	
4	E	D-IN1	Input signal 1	202	
5	F	D-IN2	Input signal 2	203	
6	G	D-IN3	Input signal 3	204	
7	H	D-IN4	Input signal 4	205	
8	J	P24G	0 V		
	K	Not used			
10	L	D-OUT0	Output signal 0	201	
11	M	D-OUT1	Output signal 1	202	
12	N	P24V	24 V		
13	P	D-OUT2	Output signal 2	203	
14	R	D-OUT3	Output signal 3	204	
15	S	P24V	24 V		
9	T	Shield (FG)			

Input/output signal connector CN0 (Type-P)

Pin (D-SUB)	Pin (Cannon)	Signal name	Signal No.	Input/output circuit and example of connections	
	A	Not used			
	B	Not used			
	C	Not used			
3	D	D-IN0	Input signal 0		201
4	E	D-IN1	Input signal 1		202
5	F	D-IN2	Input signal 2		203
6	G	D-IN3	Input signal 3		204
7	H	D-IN4	Input signal 4		205
8	J	P24V	24 V		
	K	Not used			
10	L	D-OUT0	Output signal 0	201	<p>Plus common (X8GI)</p>
11	M	D-OUT1	Output signal 1	202	
12	N	P24G	0 V		
13	P	D-OUT2	Output signal 2	203	
14	R	D-OUT3	Output signal 3	204	
15	S	P24G	0 V		
9	T	Shield (FG)			

As input signals, no-voltage contacts or transistor open collector inputs are used.

No-voltage contact specifications:

Contact rating: DC24 V, 10 mA or over (circuit current: approx. 7 mA)

Minimum contact current: DC24 V, 1 mA

Contact impedance: 100 Ω or less

Transistor specifications:

Withhold voltage between collector and emitter: 30 V or over

Current between collector and emitter: 10 mA or over (circuit current: approx. 7 mA)

Leak current between collector and emitter: 100 μ A or less

By using P24V power of the controller, a relay, solenoid valve, etc., can be driven.

When the external power is used, GND of the external power should be common to GND (P24G) of the robot controller.

Output specifications:

Rated voltage : DC24 V (max. DC30 V)

Rated current : 100 mA

- If the P24V power supplied from the robot controller is used, the total current should be 2 A or less.
- When the external power is used, the total current should also be 2 A or less.
- When a relay or solenoid valve, etc., is connected, it is necessary to use a surge killer or diode to absorb the surge voltage.

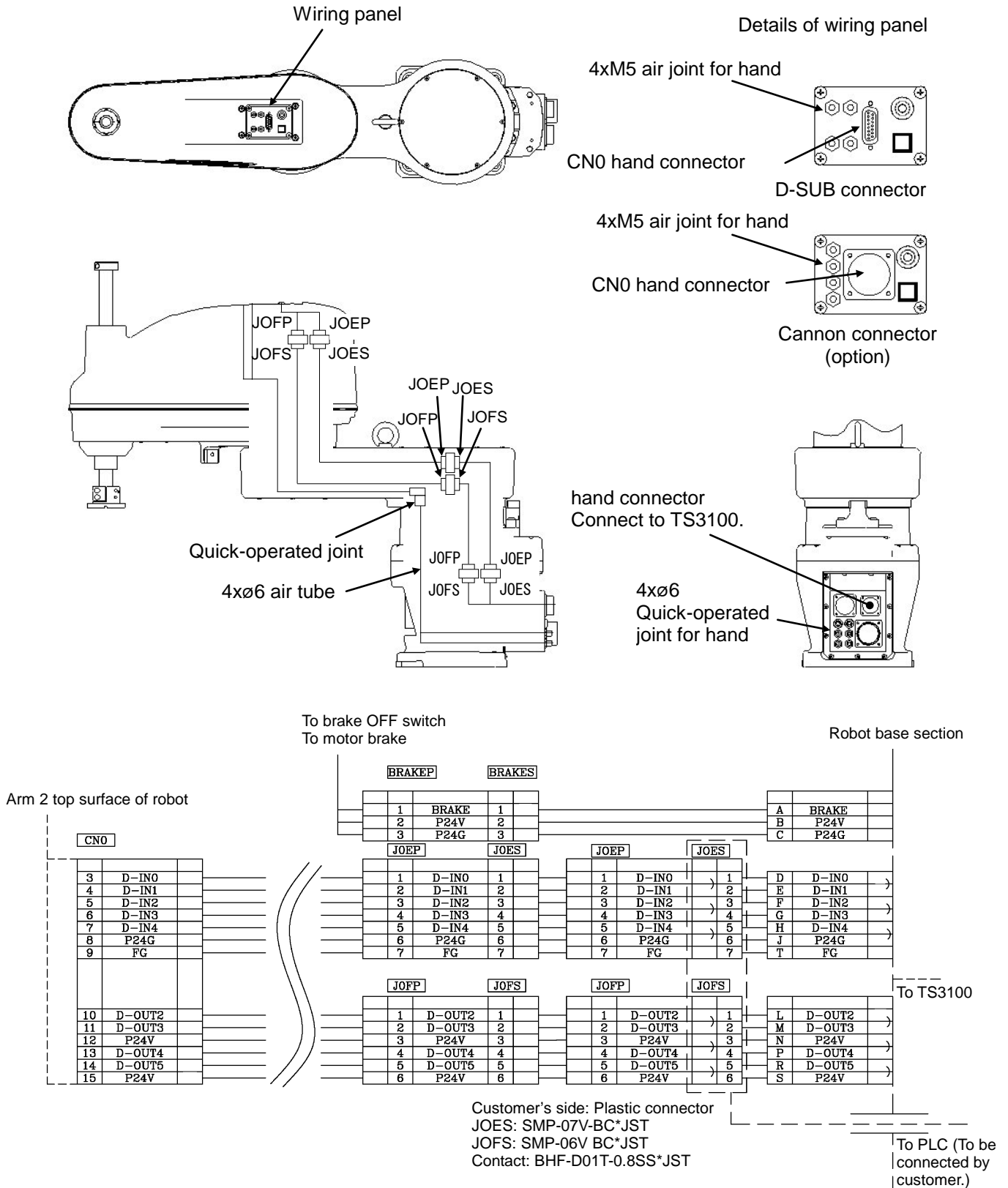

Fig. 5.3 Tool wiring

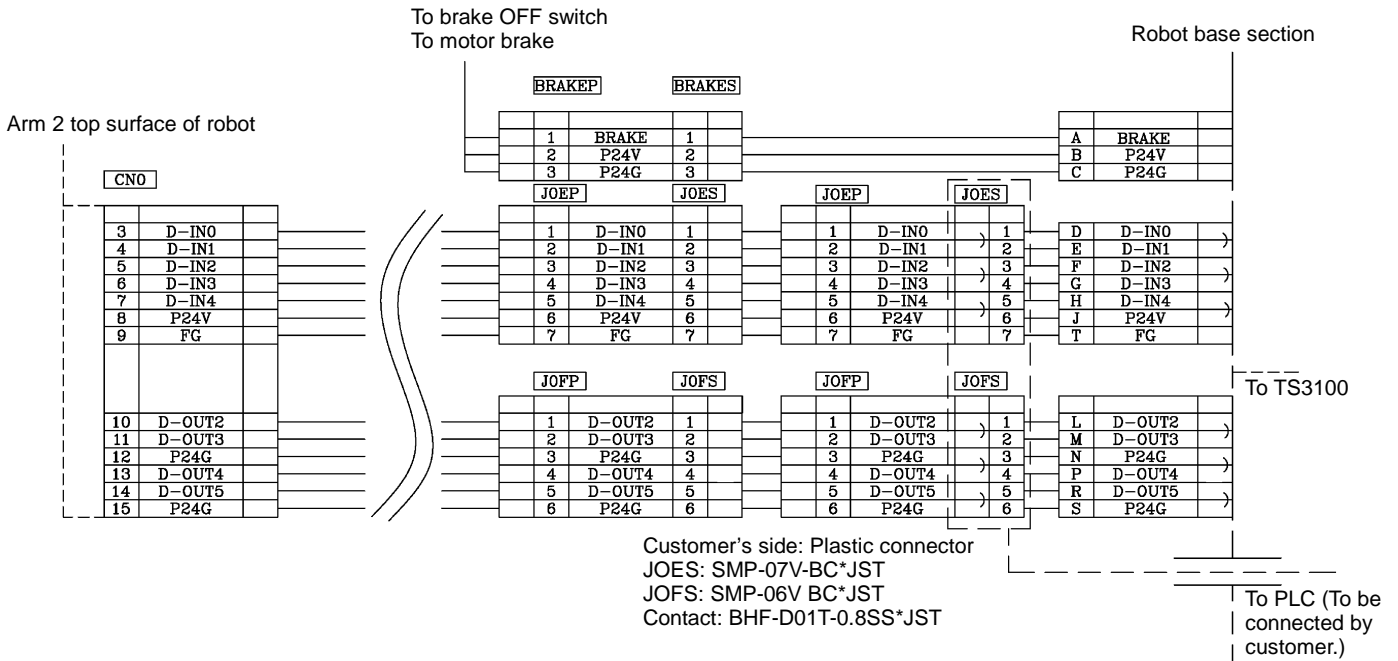
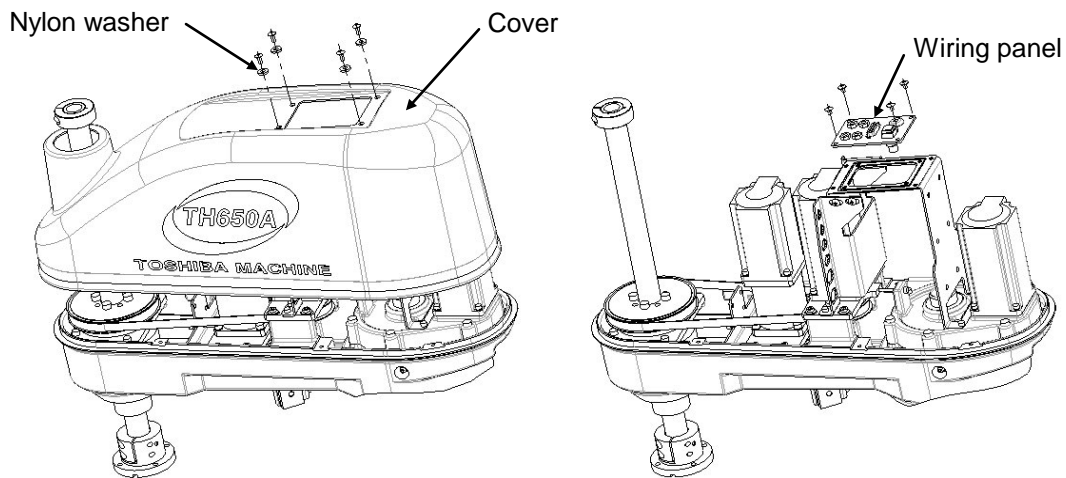

Fig. 5.4 Tool wiring (Type-P)

The cables are connector-connected at the upper side of the arm 2 cover. The wiring panel on the upper side of the same cover can also be mounted on the lower side of the arm 2. The following three (3) manners are available for the tool wiring and piping.

- Wiring and piping to the tool through a hollow hole (18 mm-dia.) on the tool shaft.
- Wiring and piping, using fixed stays.
- Direct wiring and piping by relocating the wiring panel to the lower side.

Fig. 5.5 and Fig. 5.6 show the procedures for relocating the wiring panel and the wiring method, respectively.



1. Remove the four (4) screws securing the cover, then draw it upward and disconnect.
2. Remove the four (4) screws securing the wiring panel, then dismount the wiring panel. As all cables are connector-connected, disconnect all cables connected there. The gasket for the panel should remain attached to the steel plate securing the cover.

Connectors to be removed in Step 2:
 JOEP, JOFP, JOES, JOFS
 Brake OFF switch cable, four (4) air tubes

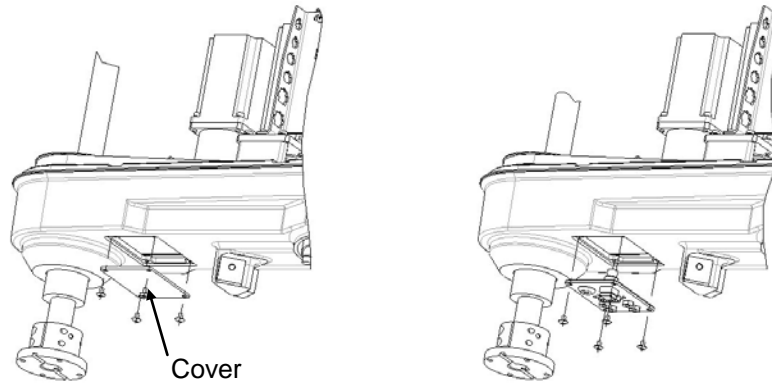

3. Remove the cover at the lower side of the arm 2.

4. Mount the wiring panel which was dismantled in Step 2.

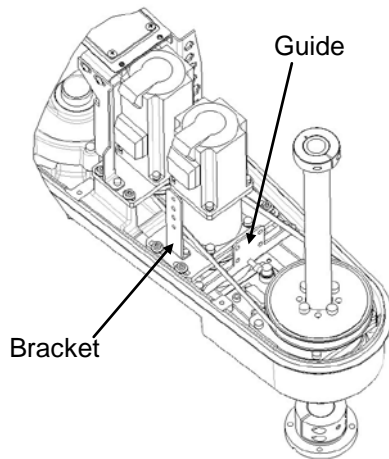

5. The cables connecting the panel with the actuator are fabricated long so that the panel can be mounted on the lower side, and are secured to the bracket with TY-RAP. Cut the secured TY-RAP, using nippers, etc., extend the cables, then connect the connectors coming from the panel. After the connection, secure the cables to the guide, using the TY-RAP so that the cables will not collide with the axis 3 or 4 belt. Secure any loosened cable to the bracket also, using the TYRAP.

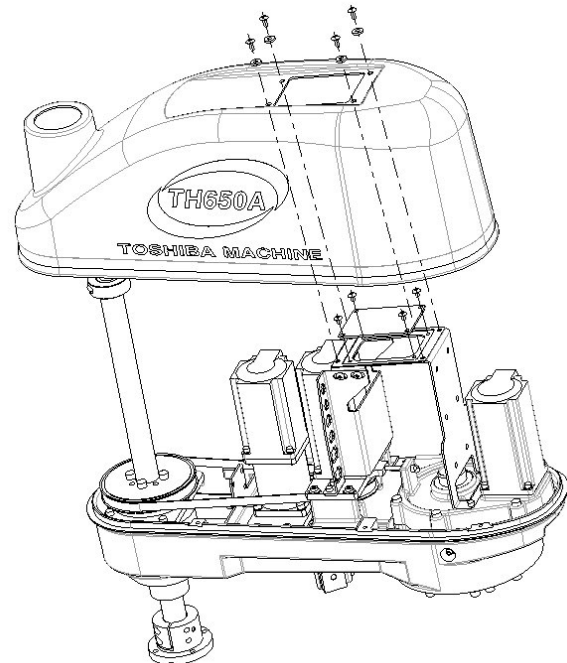

6. Finally, secure the cover disconnected in Step 3 to the location where the panel was mounted before, then attach the cover. At this time, be sure to set the nylon washers. Take careful precautions not to damage the cover.

Fig. 5.5 Procedures for relocating wiring panel



CAUTION

- Be sure to connect all connectors properly. Otherwise, the robot may malfunction.
- Take careful precautions not to interfere the cables with the belts. Otherwise, the cables may break.
- When relocating the panel, take utmost care not to damage the belts.

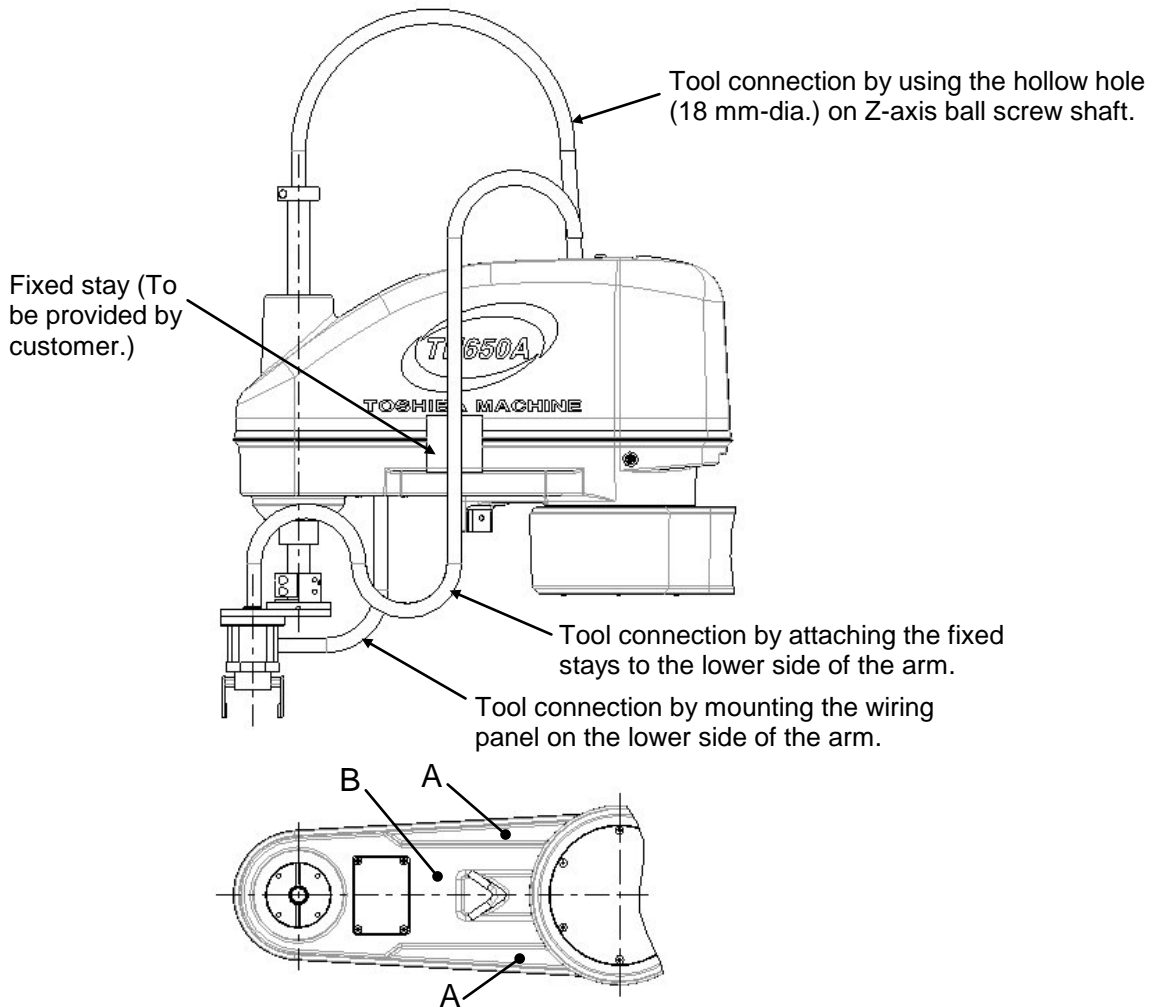

Fig. 5.6 Wiring method

Note: For the tap holes on the lower side of the arm 2, which are used to attach the fixed stays, it is recommended to machine surfaces A in the figure above. If the pre-drilled hole is under 15 mm-deep at this time, it will not go through the top surface.

Recommended tap holes machined: M4 depth 8, pre-drilled hole depth 13 mm

When machining surface B, the hole will go through the top surface (arm 2 interior). When using the robot in a clean environment, machine surfaces A and attach the stays there.



CAUTION

- Be sure to use a highly flexible robot cable, which should be secured below the arm with a cable clamp, etc. Unless a robot cable is used, the wire may be broken.
- When performing tool wiring and piping, take all necessary measures against breakage due to rub, etc.
- At robot operation, take careful precautions not to exert a load on respective connectors.

5.2.3 Tool Air Piping

The robot is provided with four (4) air lines for the tool.

The outer diameter of the air pipelines is 6 mm. Fig. 5.7 shows the tool air piping.

The air control unit (oiler, regulator with gage and filter) for the solenoid valves should be provided by the user.

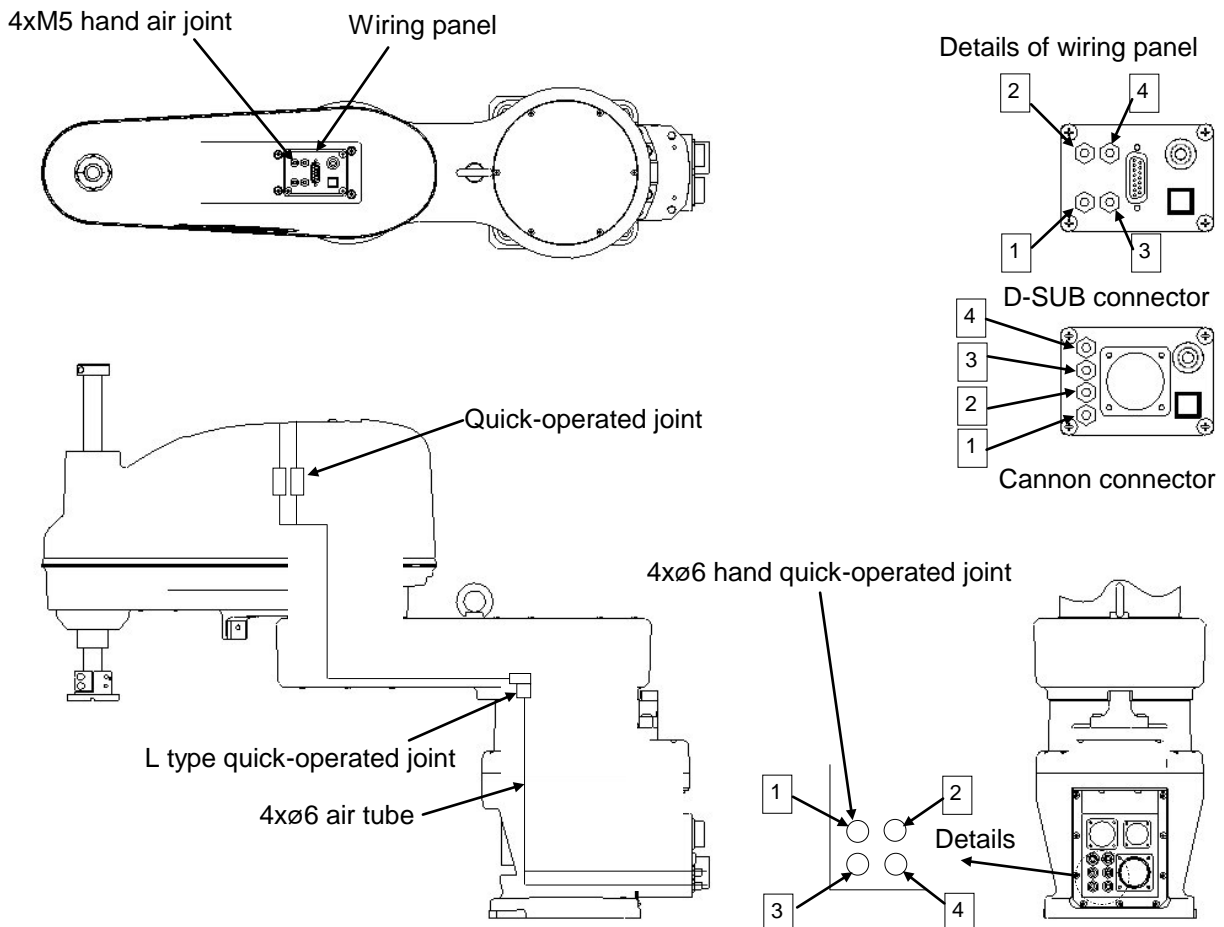

The air tube is identified by the number and color. At piping, make sure that each tube is connected properly, referring to the below-mentioned.

1 : Red 2 : White 3 : Blue 4 : Yellow

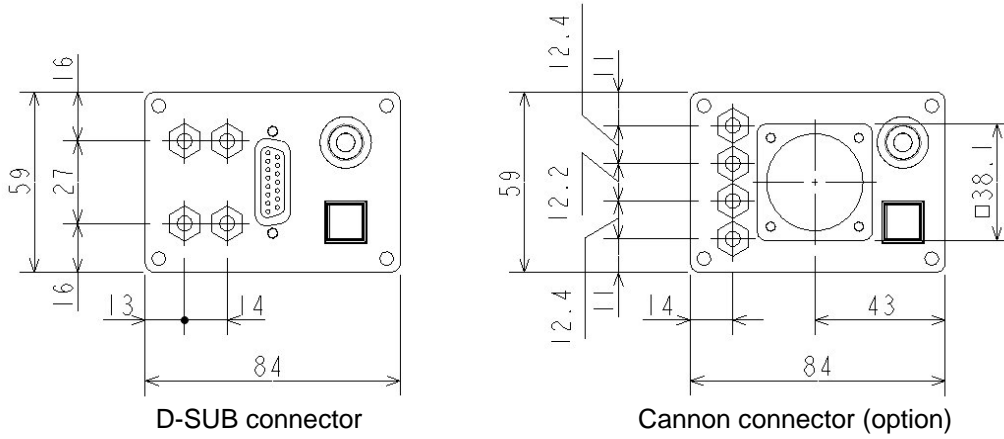

Fig. 5.7 Tool air piping

5.3 Permissible Load Conditions and Program Setting

This paragraph describes the permissible load conditions of the robot and how to set up the program according to the load.

5.3.1 Permissible Load Conditions

The robot load conditions are defined by the tool mass, moment of inertia and offset value of tool gravity center from the center of the tool shaft, as shown in Fig. 5.8.

The permissible load conditions are shown in Table 5.1.

Table 5.1 Permissible load conditions

Conditions	Permissible values
Mass	Max. 10 kg
Load inertia	Max. 0.10 kg·m ²
Offset value of load gravity center	Max. 100 mm



CAUTION

- NEVER operate the robot under the load conditions exceeding the permissible values. Otherwise, the robot life and safety cannot be guaranteed.

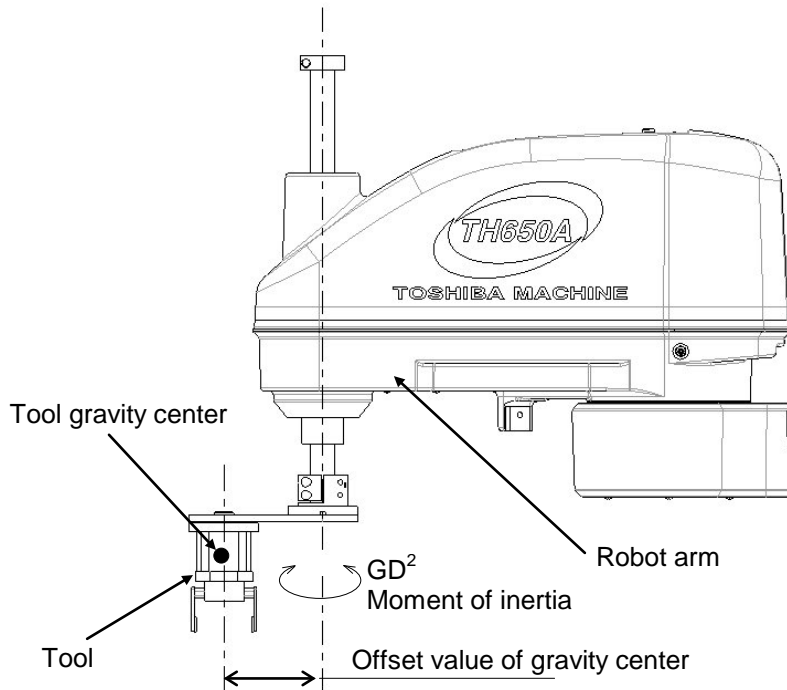

Fig. 5.8 Robot tool

5.3.2 Load Conditions and Program Setting

This robot can automatically change the maximum speed, acceleration/deceleration and servo gain by using the PAYLOAD command in the program according to the load conditions.

Be sure to use the PAYLOAD command.

The specific method for using this function is explained below.

a) PAYLOAD command format

The PAYLOAD command format is written as shown below if the tool mass is M kg and the gravity center offset is L mm.

$$\text{PAYLOAD} = \{M, L\}$$

M : Load mass (unit: kg)

L : Offset value of gravity center (unit: mm)

The PAYLOAD command has the following functions.

- The maximum speed and acceleration/deceleration of each robot axis are automatically changed according to the set load conditions.

- The servo gain of each robot axis is automatically changed according to the set load conditions.

b) Program examples

Basic program examples using the PAYLOAD command are shown below. For further information, see the Robot Language Manual.

(Program example 1)

The robot is moved under the load conditions of 5 kg mass and 100 mm gravity center offset.

```
PROGRAM SAMPLE
SPEED=100
PAYLOAD={5,100}
MOVE P1
MOVE P2
STOP
END
```

(Program example 2)

When the hand mass is 3 kg and the gravity center offset is 30 mm, and the mass is 5 kg and gravity center offset is 50 mm when the workpiece is grasped.

Pick-and-place operation is executed under the above conditions.

```
PROGRAM SAMPLE
PAYLOAD={3,30}
ACCUR=COARSE
ENABLE NOWAIT
RESET DOUT
MOVE P0
DOUT(1)
WAIT DIN(1)
LOOP:
MOVE P1+POINT(0,0,100)
IF DIN(-1)THEN GOTO FIN
MOVE P1
WAIT MOTION>=100
DOUT(213)
DELAY 1
PAYLOAD={5,50}
MOVE P1+POINT(0,0,100)
MOVE P2+POINT(0,0,100)
MOVE P2
WAIT MOTION>=100
DOUT(-213)
```

```

DELAY 1
PAYLOAD={3,30}
MOVE P2+POINT(0,0,100)
GOTO LOOP
FIN:
MOVE P0
DOUT(1)
STOP
END
    
```

c) Setting of PAYLOAD command

In the default state, or when the PAYLOAD command is not used, the maximum speed and acceleration/deceleration are set to 100 % and the servo gain is set to the value under the minimum load. (See Para. 5.3.3.)



CAUTION

- Be sure to use the PAYLOAD command.
- Unless the PAYLOAD command is used, the robot will vibrate or overshoot, resulting in malfunction or shortening of the life of the mechanisms. In the worst case, the mechanism will be damaged.
- Even when the PAYLOAD command is used, regulate the speed by using the SPEED or DECEL command while confirming the workpiece behavior subject to handling.



CAUTION

- The load moment of inertia should be within the tolerances given in Table 5.1.
- Even if there is no offset of load gravity center, if the moment of inertia is large, the robot may vibrate. When this happens, figure out the virtual gravity center offset (L mm) from the following equation, using the moment of inertia (J kg·m²) and mass (M kg).

$$L = \sqrt{(J \times 10^6 / M)}$$

Then, designate the following command.

PAYLOAD = {M, L}



CAUTION

- When guiding manually, the robot may vibrate if the load mass or gravity center offset is large. This is because the servo gain is not appropriate. When this happens, perform the following operation while setting the load conditions in the test run mode.

DO PAYLOAD = {M, L} M: Mass [kg] L: Offset [mm]

EXE

The servo gain is changed then to the value which meets the load conditions.

5.3.3 Setting Maximum Speed and Robot Acceleration/Deceleration for Load Conditions

When the PAYLOAD command is used, the maximum speed and acceleration/deceleration of the robot are automatically changed according to the load conditions.

The maximum speed and acceleration/deceleration change with the load mass, as shown in Fig. 5.9.

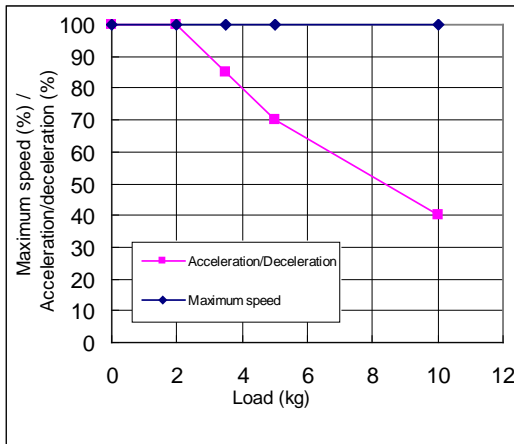

Setting of maximum speed and acceleration/deceleration in relation to load mass (Axis 1)

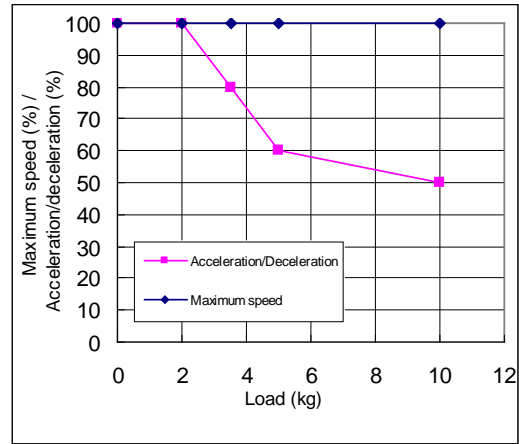

Setting of maximum speed and acceleration/deceleration in relation to load mass (Axis 2)

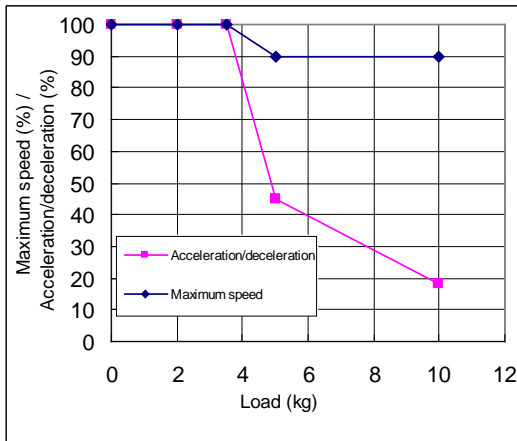

Setting of maximum speed and acceleration/deceleration in relation to load mass (Axis 3)

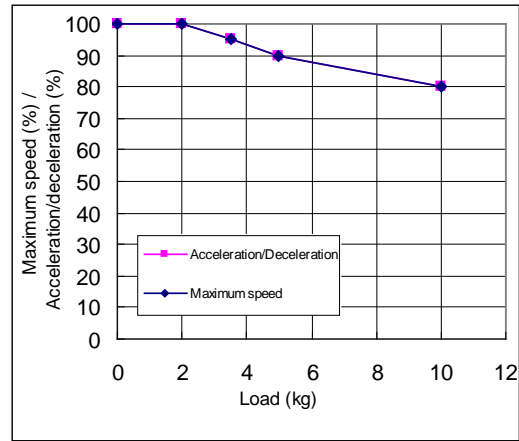

Setting of maximum speed and acceleration/deceleration in relation to load mass (Axis 4)

Fig. 5.9 Setting of maximum speed and acceleration/deceleration in relation to load mass

Additionally, if there is an offset of load gravity center, the maximum speed and acceleration/deceleration change as shown in Fig. 5.10 and Fig. 5.11. For the axis 3, however, no restriction is imposed on the offset.

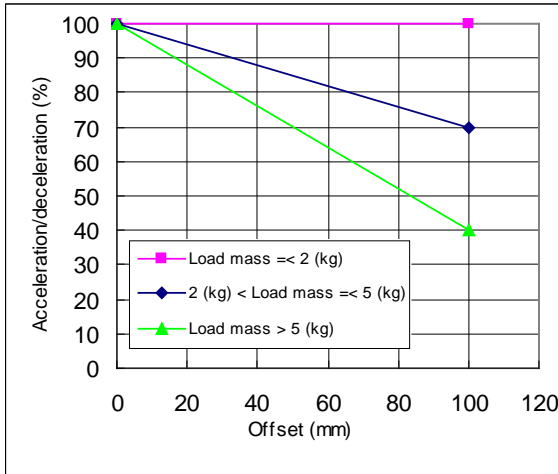

Setting of acceleration/deceleration in relation to offset (Axis 1)

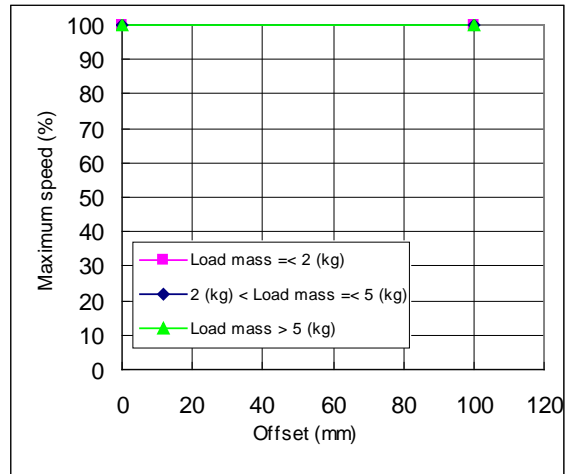

Setting of maximum speed in relation to offset (Axis 1)

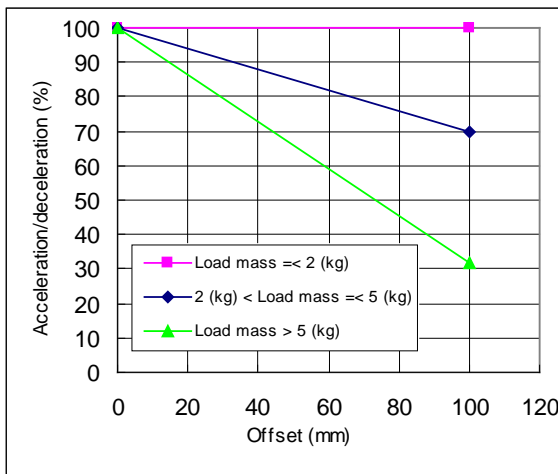

Setting of acceleration/deceleration in relation to offset (Axis 2)

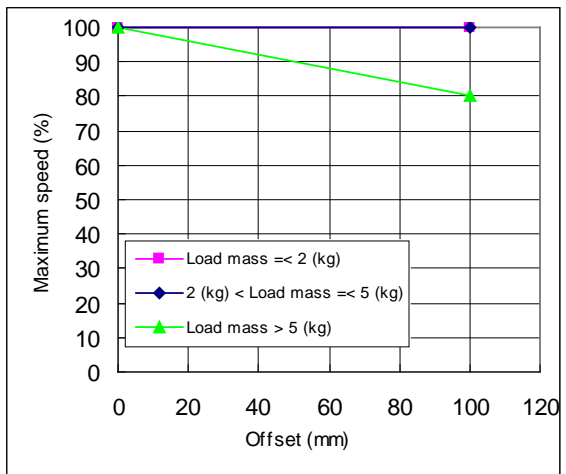

Setting of maximum speed in relation to offset (Axis 2)

Fig. 5.10 Setting of maximum speed and acceleration/deceleration in relation to gravity center offset (Axes 1 and 2)

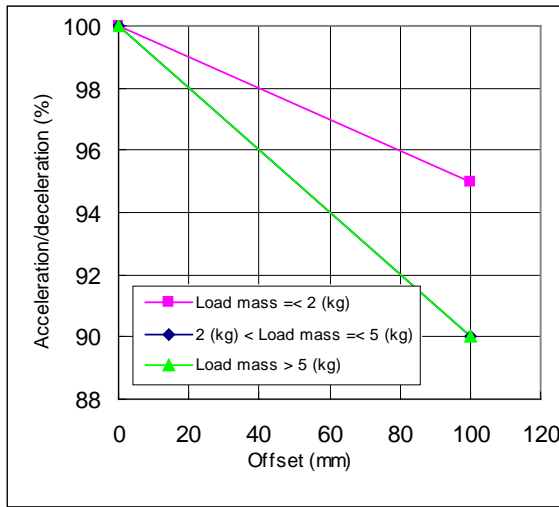

Setting of acceleration/deceleration in relation to offset (Axis 3)

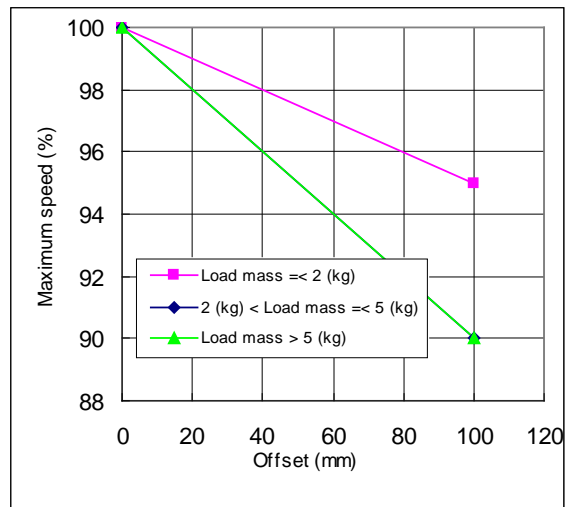

Setting of maximum speed in relation to offset (Axis 3)

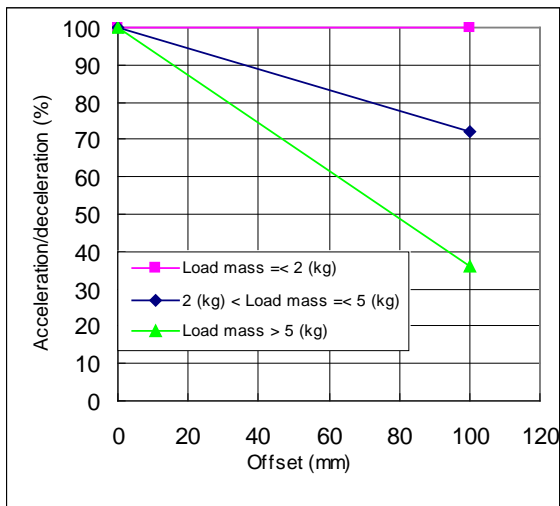

Setting of acceleration/deceleration in relation to offset (Axis 4)

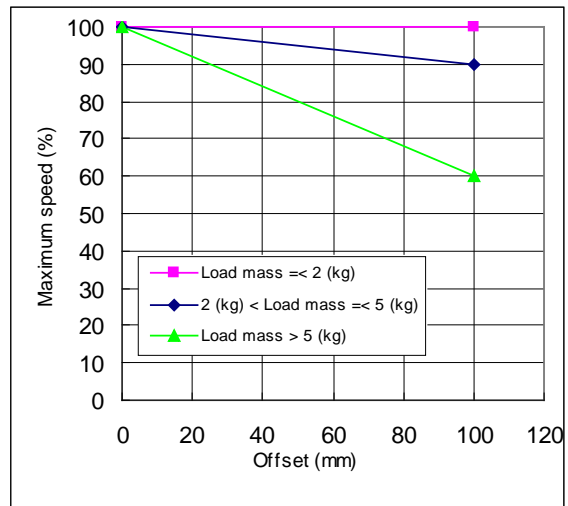

Setting of maximum speed in relation to offset (Axis 4)

Fig. 5.11 Setting of maximum speed and acceleration/deceleration in relation to gravity center offset (Axes 3 and 4)