



CIMON Panel-PC

- 12", 15" and 19"
- Compact - fan-less
- Windows 8.1®



Technical Data

Model		CM-NP12-A	CM-NP15-A	CM-NP19-A
Display		12" TFT LCD	15" TFT LCD	19" TFT LCD
Resolution		XGA (1024 x 768)		SXGA (1280 x 1024)
Color		16,7 mio		
Backlight		LED		
CPU		Intel Baytrail-I Embedded Processor E3845 Quad Core 1.91GHz		
Touchscreen		8-wire Analog Resistive		
Memory		Standard: 4GB DDR3 SDRAM 2CH		
Storage		128GB mSATA SSD		
Graphic		Intel Graphic HD4000 (integrated)		
LCD Brightness		500cd/m2	450cd/m2	250cd/m2
Interface	Serial	3 x RS232C 1 x RS422/485		
	Ethernet	Gigabit Ethernet, 2 x RJ45		
	USB	4 x USB 2.0	6 x USB 2.0 (2 x front)	
	Sound	1 x Line Out; 1 x Mic In		
	Ex. Storage	1 x mSATA (max. 120GB SSD)		
Operating System		Windows Embedded Standard 8.1 Industry Pro*		
Programs		EWF (OS protection) / UWF / RESCUE (OS initialization)		
Power Input		100 ... 240V AC		

* On request: Windows Embedded Standard 7 Pro

Dimensions W x H x D [mm]

	CM-NP12-A	CM-NP15-A	CM-NP19-A
B1	330	395	480
B2	318	381	462
B3	319	382	463
H1	250	310	390
H2	238	296	371
H3	239	297	372
T1	82	89	124

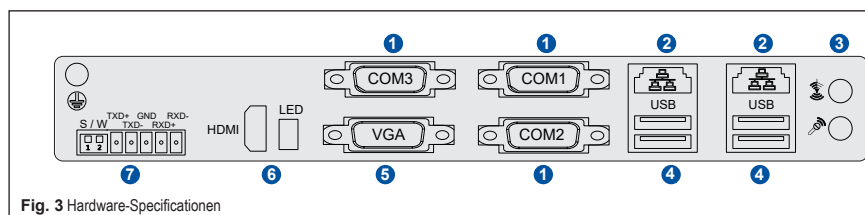
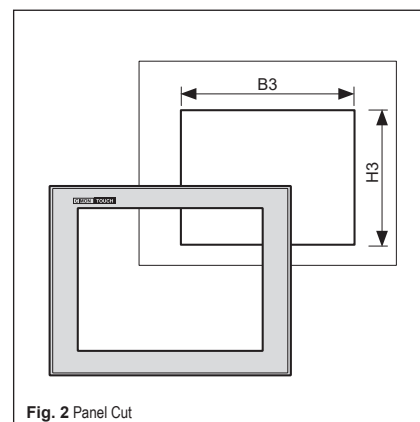
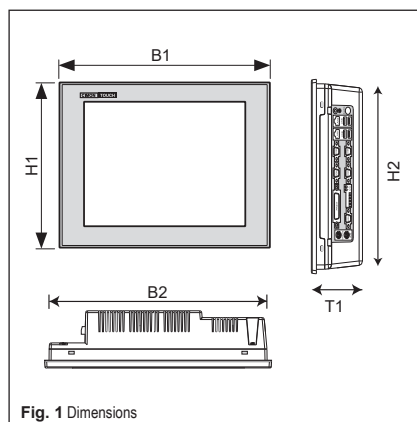

Hardware-Spezifikationen

1	COM 1 / COM 2 / COM 3 (RS-232C)
2	LAN 1 / LAN 2
3	Sound: Line Out, Mic In
4	USB 2.0
5	VGA Out
6	HDMI / LED
7	COM 4 (RS-422 / RS-485)